

Protect Series Safety Controllers...

*The next generation of
multi-function safety relay modules.*

SCHMERSAL is pleased to introduce their newest family of safety controllers. Designated the PROTECTSM Series, this product family features:

- Detachable wiring terminals ... to facilitate easier installation and maintenance.
- Electronic fuses ... eliminating the need for time-consuming fuse replacement.
- Diagnostic LEDs for safety relay output status, fuse status and input voltage status ... to minimize downtime.
- Multi-voltage models ... compatible with a wide range of supply voltages.
- Single or Dual-Channel operation ... for application versatility.
- Cross-short recognition and motor contactor or machine control relay contact monitoring ... to enhance system safety.
- Suitable for Safety Control Category 4 applications per EN954-1 ... to satisfy even the highest assessed-risk applications.
- DIN-rail mounting ... for ease of installation.
- Dry-contact and PNP-switching input compatibility ... accept a wide variety of monitored devices (such as E-stops, safety interlock switches, safety light curtains, ...)

The following pages provide detailed specifications and installation suggestions for this versatile range of general-purpose safety circuit monitors with control and display capability.

TABLE OF CONTENTS

Topic	Page
Protect sm Series Safety Controller Selection Guide	4
Alphanumeric Product Index	5
Risk Assessment	7
Achieving “Control Reliability”	8
Basic Function	10
Safety Controller Selection Criteria	11
Frequently Asked Questions Regarding Safety Controllers	26
Selected Machine Safeguarding Terminology	28

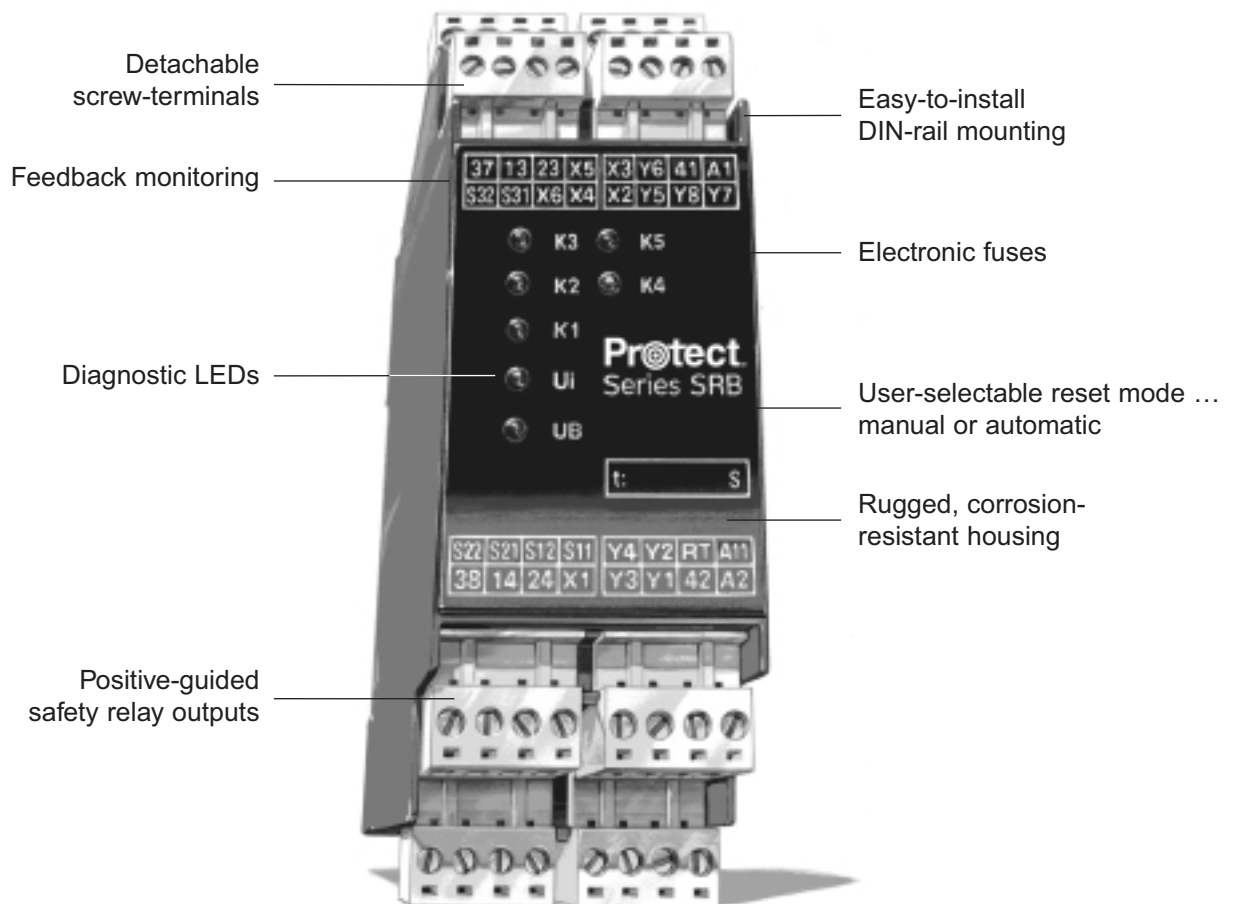

ProtectSM SERIES

SAFETY CONTROLLERS

SELECTION GUIDE

Model	Operating Voltage (U _e)	Types of Inputs Monitored	Number of Input Devices Monitored	Number of Safety Outputs	Number of Auxiliary Outputs	Feedback Monitoring	Type of Reset	Cross-short Monitoring
SRB 201 ZH	24VDC	Two-hand control (dry contacts)	2	2	1 N.C.	Yes	Automatic	Yes
SRB 206 ST*	24VAC/DC or 48-230VAC	Dry contacts	6	2	6 (Semi-conductor)	Yes	Monitored-manual or Automatic	No
SRB 206 SQ*	24VAC/DC or 48-230VAC	Dry contacts	6	2	6 (Semi-conductor)	Yes	Monitored-manual or Automatic	Yes
SRB 211 ST	24VAC/DC	Dry contacts or PNP-type outputs	1	2 (stop category 0) 1 (stop category 1)	1 N.C.	Yes	Monitored-manual or Automatic	Yes (selectable)
SRB 301 LC & SRB 301 LCI	24VAC/DC	Dry contacts or PNP-type outputs	1	3	1 N.C.	Yes	Manual or Automatic	Yes (selectable)
SRB 301 ST	24VAC/DC	Dry contacts or PNP-type outputs	1	3	1 N.C.	Yes	Monitored-manual or Automatic	Yes (selectable)
SRB 301 ST-230V	48V-230VAC	Dry contacts	1	3	1 N.C.	Yes	Monitored-manual or Automatic	No
SRB 301 SQ-230V	48V-230VAC	Dry contacts	1	3	1 N.C.	Yes	Monitored-manual or Automatic	Yes

*Suitable for use in systems designed for up to Safety Control Category 3 per EN954-1.
All others are suitable for use in systems up to Safety Control Category 4 per EN954-1.

DIFFERENTIATED-INPUT SAFETY CONTROLLERS

SRB 202 C	24VDC	Dry Contacts	2	2	2 N.C.	Yes	Depends upon model*	Depends upon model*
SRB 400 C	24VDC	Dry Contacts	2	4	None	Yes	Depends upon model*	Depends upon model*

*Please see selection chart on Page 22.

SAFETY OUTPUT EXPANSION MODULE

SRB 402 EM	24VAC/DC	N/A	N/A	4	2 N.C.	Yes	Automatic	N/A
------------	----------	-----	-----	---	--------	-----	-----------	-----

ALPHANUMERIC PRODUCT INDEX

Product	Page
SRB 201 ZH	12
SRB 202 C	22
SRB 206 ST	14
SRB 206 SQ	14
SRB 206 SQ-230	14
SRB 211 ST	16
SRB 301 LC	18
SRB 301 LCI	18
SRB 301 ST	20
SRB 301 ST-230	20
SRB 301 SQ-230	20
SRB 400 C	22
SRB 402 EM	24

ProtectSM Series Safety Controllers

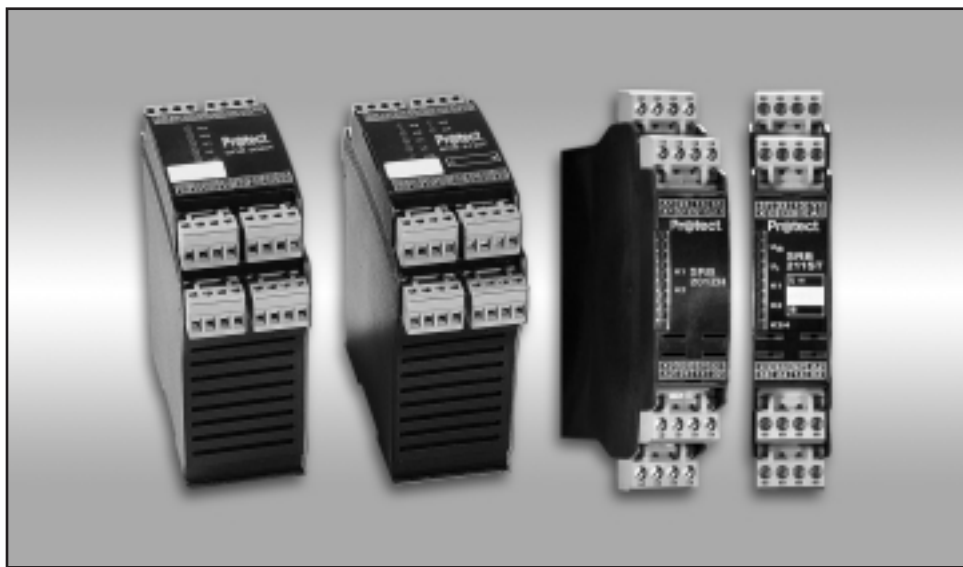

INTRODUCTION

SELECTING THE OPTIMAL CONTROLLER

Some form of safety controller is required to meet higher risk categories of the European safety standards, to meet OSHA/ANSI requirements for Control Reliability, and when using coded-magnet switches as safety interlocks. This guide is intended to help you properly select and apply Schmersal Safety Controllers.

It is common for all of us to want to look at safety issues in black and white terms (“Here is Application Number 116 and I can find the solution in my Safety Handbook under Solution Number 116”). Unfortunately, this is seldom possible. You are forced to look at safety issues in various shades of gray. For any given situation, there may be a number of correct solutions depending on total system design.

A safe machine is generally achieved through the combination of safety measures incorporated by design and taken by the machine operator. Ideally such measures should be addressed during the design phase. In addition proper training of machine operators and maintenance personnel is critical for safe operation.

While individual component suppliers can provide general guidance and technical information related to their products, it is the responsibility of the machine designer or retrofitter to ensure the safety system is designed to meet the appropriate standards.

To minimize the possibility of worker injury and address industry safety standards/guidelines, it is recommended that the machine designer follow these general steps:

- (1) Familiarize himself with the pertinent safety standards.
- (2) Recognize and identify the limits of the machine.
- (3) Identify the hazards and assess the risks ... during set-up, operation, and maintenance procedures.
- (4) Remove the hazards or limit the risk by design.
- (5) For remaining hazards, install necessary protective devices.
- (6) Inform and warn the operator of any remaining risks/hazards.

In designing a machine guarding safety system, the following objectives should be considered:

- Design to suit the working environment.
- Achieve the desired degree of protection.
- Do not interfere with machine operation.
- Do not encourage manipulation/bypassing.
- Make it difficult to override/bypass.
- Do not cause any additional dangers/hazards.

It is impossible to correctly select and apply a Safety Controller without performing some type of quantitative risk assessment. “Guesstimating” a control category may lead to excessive expense and/or to an inadequate or unsafe system. There are a number of approaches to risk assessment, most of which use some form of decision tree to determine the appropriate safety control category. One such approach is discussed in the next section.

Note: For additional background material, you may wish to review Schmersal’s “Man-Machine Safeguarding Requirements & Techniques.” This tutorial booklet and associated videos provide an overview of basic machine safeguarding concepts and terminology.



RISK ASSESSMENT

Different machines and processes have different levels of relative risk. Determining this relative risk level involves evaluating three major factors. These include:

- (1) Severity of the potential injury.
- (2) Frequency of exposure to the potential hazard.
- (3) Possibility of avoiding the hazard if it occurs.

One approach to risk assessment provides guidelines for determining the safety control system requirements based upon five levels of risk. These levels range from the lowest risk (level B) in which the severity of injury is slight and/or there is relatively little likelihood of occurrence, to the highest risk (level 4) in which the likelihood of a severe injury (if the safety control system fails) is relatively high.

This particular method is depicted in Figure 1, in which the following qualitative definitions apply:

- S: Severity of potential injury
 S1: slight injury (bruise)
 S2: severe injury (amputation or death)
- F: Frequency of exposure to potential hazard
 F1: infrequent exposure
 F2: frequent to continuous exposure
- P: Possibility of avoiding the hazard if it occurs (generally related to the speed/frequency of movement of hazard point and distance to hazard point)
 P1: possible
 P2: less possible

The levels of risk and related safety control system requirements are defined in Figure 2.

These safety control system categories are not to be regarded as a hierarchy. The goal is to reduce the ultimate risk of all machines to acceptable levels regardless of initial assessed risk.

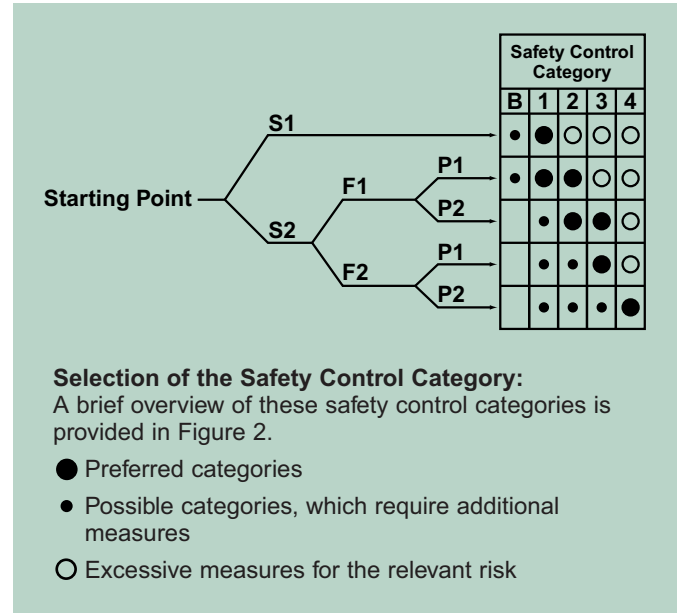

FIGURE 1

FIGURE 2

Safety Cat.	General Safety System Requirements	General Safety System Behavior	Safety Cat.	General Safety System Requirements	General Safety System Behavior
B	Safety system designed to meet operational requirements and withstand expected external influences. (This category is usually satisfied by selecting components compatible with the application conditions ... e.g. temperature, voltage, load, etc.)	A single fault or failure in the safety system can lead to the loss of the safety function.	3	Safety system must meet the requirements of Category B. In addition the safety control system must be designed such that a single fault will not lead to the loss of the safety function. And, where practical, the single fault will be detected. (This requires redundancy in the safety circuit monitoring module and the use of dual-channel monitoring of the input and output devices such as machine guard interlock switches, E-stop pushbuttons, safety relays, etc.)	Here a single fault or failure in the safety system will not lead to the loss of the safety function and, where possible, will be detected.
1	Safety system must meet the requirements of Category B, but must use "well-ried" safety principles and components. "Well-ried" principles and components include those which: <ul style="list-style-type: none"> • avoid certain faults ... e.g. short circuits. • reduce probability of faults ... e.g. over-rating selected components, over-dimensioning for structural integrity. • detect faults early ... e.g. ground fault protection. • assure the mode of the fault ... e.g. ensure an open circuit when it is vital that power be interrupted should an unsafe condition arise. • limit the consequences of the fault. 	A single fault or failure in the safety system can lead to the loss of the safety function. However, the use of "well tried" safety principles and safety components results in a higher level of safety system reliability.	4*	Safety system must meet the requirements of Category B. In addition the safety control system must be designed such that a single fault will not lead to the loss of the safety function and will be detected at or before the next demand on the safety system. If this is not possible, then the accumulation of multiple faults must not lead to the loss of the safety function. (This also requires redundancy in the safety circuit and the use of dual-channel monitoring of the input and output devices such as machine guard interlock switches, E-stop pushbuttons, safety relays, etc. Here the number of allowable faults will be determined by the application, technology used, and system structure.)	Here a single fault or failure in the safety system will not lead to the loss of the safety function, and it will be detected in time to prevent the loss of the safety function.
2	Safety system must meet the requirements of Category B. In addition the machine shall be prevented from starting if a fault is detected upon application of machine power, or upon periodic checking during operation. (Single-channel operation is permitted provided that the input devices ... such as machine guard interlocks, E-stop pushbuttons, et al ... are tested for proper operation on a regular basis.)	Here, too, a single fault or failure in the safety system can lead to the loss of the safety function between the checking intervals. However, periodic checking may detect faults and permit timely maintenance of the safety system.	*Category/Level 4 safety requirements are usually associated with extremely high-risk applications. Since general machine design practice respects classic safety hierarchy, in which most machine hazards are either: <ul style="list-style-type: none"> • designed out, • guarded against (if they cannot be designed out), and, • (as a last resort) warned against, Level 4 requirements may arise relatively infrequently.		

ACHIEVING “CONTROL RELIABILITY”

“Control Reliability” as defined by ANSI/OSHA essentially states that the safety system be designed, constructed and installed such that the failure of a single component within the device or system should not prevent normal machine stopping action from taking place — but shall prevent a successive machine cycle from being initiated until the failure is corrected.

Note that this definition closely follows the definitions of a safety control category 3 as defined by European machinery safety standard EN954-1.

It is helpful to break down the definition of Control Reliability in order to better understand how it might be achieved.

- Any single fault shall not lead to a loss of the safety function. This strongly implies redundancy in the safety circuit.

- Successive machine cycles shall be prevented until the fault is corrected. This means the fault must be detected. This is achieved by cross-monitoring of the redundant safety circuits.
- The device that is cross-monitoring (safety controller) must also be checked to prevent a loss of the safety system due to a fault in this device.

Thus the following are required to achieve “Control Reliability”:

- Redundancy
- Fault Detection
- Cross-short Monitoring
- Self-checking of the monitoring device

Let’s look at a basic safety system and develop it to a control reliable level.

Assuming the components are selected with appropriate electrical ratings and agency approvals, this system will generally meet Category B requirements per the European standards.

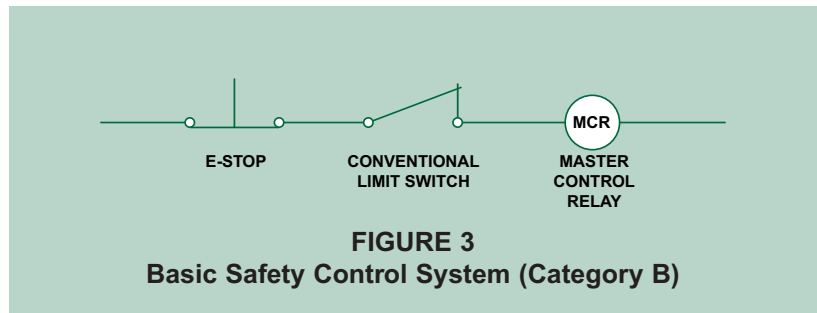

We can improve the safety system reliability by using an E-Stop and a safety interlock switch with positive-break contacts. This will generally meet Category 1 requirements per the referenced European standards. However, it does not yet meet the requirements for “control reliability.”

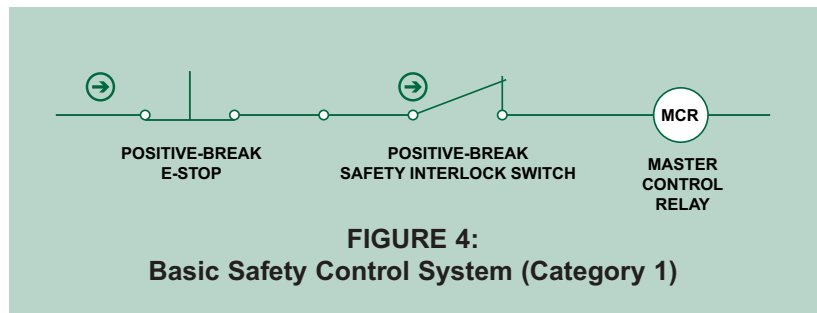

To increase the reliability, let's next add additional positive-break contacts to our E-Stop and safety interlock switch (Figure 5).

We now have redundancy but still lack fault detection. To provide this fault detection, we must add additional devices.

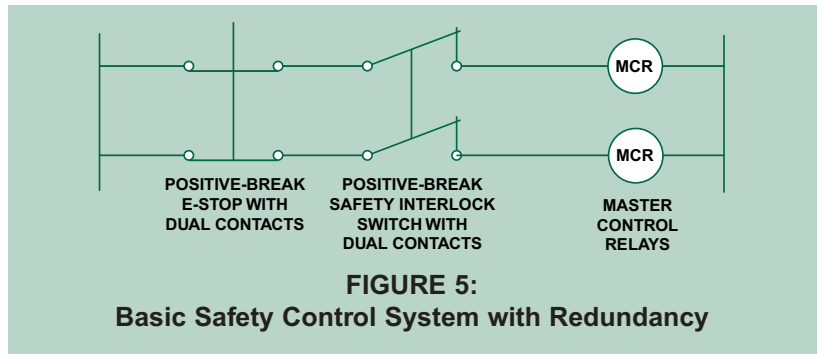

This black box provides safety system fault detection as well as cross-monitoring and self-checking. While this can be achieved with a complex hard-wired circuit utilizing multiple positive-guided relays and many wiring points, it is much simpler and less expensive to utilize a commercially available packaged safety controller.

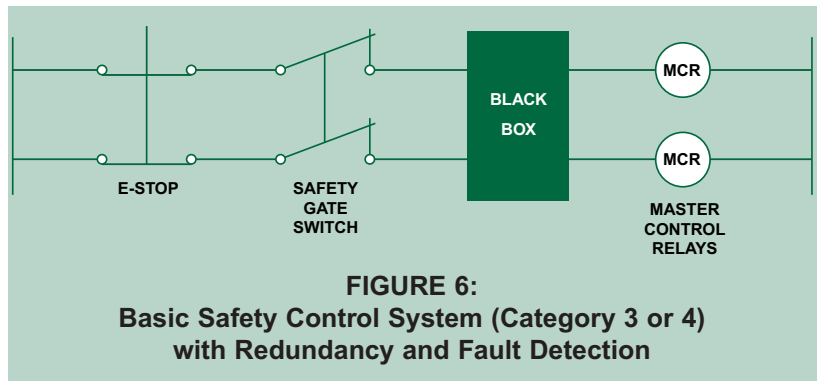
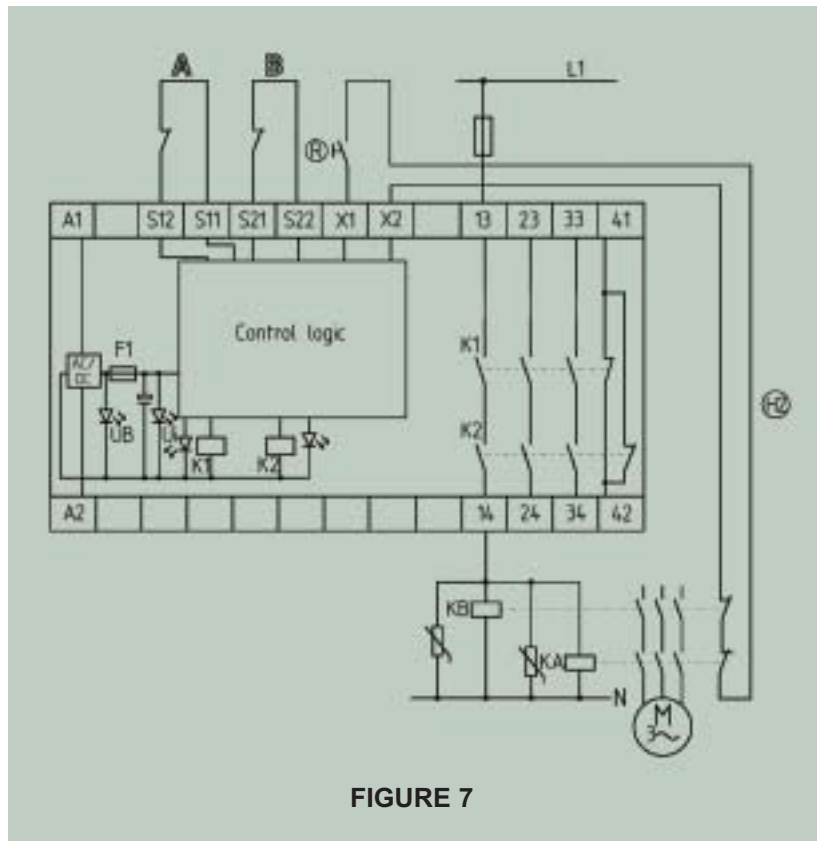

Figure 7 shows a typical example of a control reliable circuit utilizing a Series SRB 301 LC safety controller.



BASIC SAFETY CONTROLLER FUNCTIONS

The SCHMERSAL family of safety controllers includes two basic designs. One utilizes relay logic. The other uses solid-state (microprocessor) logic. Pioneered by SCHMERSAL, these “smart” safety controllers provide added features and capabilities unachievable with conventional safety relay modules.

Both designs feature redundant, dual-channel cross-monitoring logic circuits. These continuously check for, and detect, faults in the system’s safety circuit components and interconnection wiring. Modules also detect when a machine guard interlock/E-stop switch is actuated and, depending upon the model, are capable of detecting the following types of potential safety circuit faults:

- Welded interlock/E-stop switch contacts.
- Misaligned guard.
- Open circuits, short circuits or ground faults.
- Cross-short between channels.
- Welded/stuck contacts in module’s safety relays.
- Fault in the module’s monitoring circuits.
- Inadequate supply voltage to module.
- Welded/stuck contacts in controlled output motor contactor/control relay.
- Capacitive/inductive interference on module inputs.

All such controllers are designed to increase the level of safety in the machine guarding and/or E-stop control circuit.

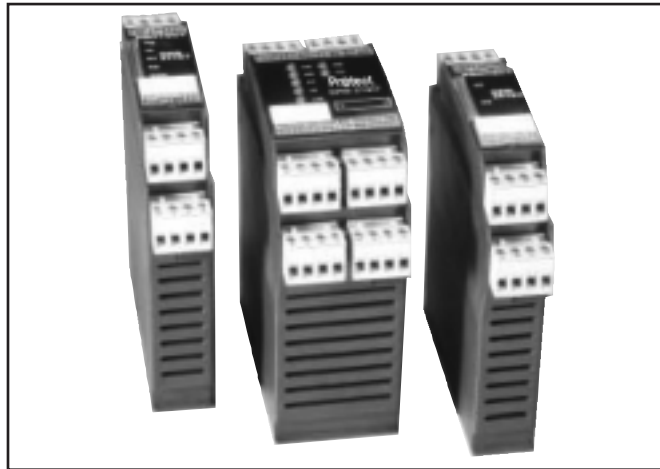

SERIES SRB SAFETY CONTROLLERS FOR GENERAL PURPOSE USE

The SRB Series safety controllers are conventional electro-mechanical relay-based units. Many feature the latest relay technology utilizing only two internal relays to achieve cross-monitoring, self-checking and redundancy. This results in a smaller, highly cost-effective solution for up to safety control category 4 system performance per European standards.

Models are available to satisfy most safety application requirements. They offer a wide variety of important features including:

- 1 or 2 channel monitoring
- Cross-short detection
- STOP Category 0 & 1 models
- Monitored-manual reset (trailing edge)
- Monitoring of dry contacts
- Monitoring of PNP-switching inputs
- Monitoring of controlled load contact welds
- Output expander module

SAFETY CONTROLLER SELECTION CRITERIA

It helps the selection process to view a safety controller as having four basic characteristics, each determined by the

application requirements. This approach can be applied to any safety controller.

FOUR BASIC SAFETY CONTROLLER CHARACTERISTICS



SUPPLY VOLTAGE REQUIREMENTS

Select your supply voltage. While many voltages are possible (24VDC, 24VAC, 24VAC/DC, 115VAC and 230VAC), 24 VDC gives the most flexibility since virtually all controllers are available in this voltage. Also, since a transformer and rectifier are not required, this unit generally is less expensive and smaller than a 115VAC model.

It is important to recognize that the safety controller supply voltage is always converted by the controller electronics to 24VDC for internal operation and for powering monitored input devices. Hence monitored input devices need only be rated for 24VDC.

INPUT MONITORING REQUIREMENTS

The first step is to determine whether you need single channel (up to Safety Control Category 2) or dual-channel (Control Category 3 & 4) operation.

Single-channel systems must monitor one N.C. positive-break contact. Dual-channel systems can monitor 1 N.O./1 N.C. or 2 N.C. contacts. Generally, these need to be isolated dry contacts since most controllers will view C-form contacts as a short circuit. Remember that 24VDC is supplied by the safety controller for monitoring these contacts.

Safety controllers are also available for monitoring non-potential free contacts (such as PNP outputs from light curtains). Models are also available that allow users to field select the monitored contact configuration.

Another consideration is crossed wire detection (a short between channels). This requires special circuitry in the safety controllers and is required for Safety Control Category 4 safety control systems.

FEEDBACK & RESET CIRCUIT REQUIREMENTS

Safety controllers with feedback capability can also monitor control relays and motor contactors with positive-

guided contacts. Such feedback is required for Safety Control Category 3 & 4 systems. A NC auxiliary contact is wired into the feedback loop (with or without a reset (start) button) to detect welded contacts in these external control devices. The safety controller detects the existence of a weld when the relay shuts down due to a power loss or open machine guard and prevents a restart.

In order to reset the controller, the feedback loop must be closed (at least temporarily). If the NC auxiliary contact stays open due to a contact weld, the controller cannot be reset.

Safety Control reset can be automatic or be achieved using the edge of a 24VDC reset signal. With automatic reset the controller will automatically reset (outputs close) when the machine guard is closed. Alternately, a reset or start button (manual reset) can be added to the feedback loop if desired. The controller only needs to momentarily see a 24VDC signal at the feedback terminals to reset.

With a monitored-manual reset, some type of pushbutton is required. For monitored-manual resets, the feedback loop circuitry is designed so that it needs to see a 24V to 0V transition (trailing edge) in order to reset. This method of reset is generally required when a person can actually get inside a machine guard (where they would be at risk if the equipment should automatically restart when the guard closes).

OUTPUT REQUIREMENTS

Determine the number and type of safety controller outputs required for machine control elements and signaling. Following are the typical types of safety controller outputs:

- A. N.O. safety enable circuits — either instantaneous or timed.
- B. N.O. or N.C. auxiliary relay contacts — these are not to be used for safety functions, but only for annunciation/signaling.
- C. Semiconductor outputs for annunciation.

Series SRB 201 ZH

Two-Hand Control Safety Controller



Description

The Model SRB 201 ZH is designed expressly for use with two-hand control units. It is equipped for connection to two actuators ... each with 1 Normally-Open (N.O.) and 1 Normally-Closed (N.C.) dry contacts. Both actuators (inputs) must be operated simultaneously (that is, within 500ms as required by EN574 type III/C requirements for machine operation to be enabled. Should the input actuators not be simultaneously operated within this specific 500ms period, both must be released before a start cycle can be initiated.

Technical Features	
Input Voltage	24 VDC
# Discrete Input Devices Monitored	2
Compatible Input Device Contact Configuration	1 N.O. & 1 N.C. (Dry Contacts)
Number & Type Safety Outputs	2 N.O. (Dry Contacts)
Number & Type Auxiliary (Non-Safety or Signalling Output)	1 N.C. (Dry Contact)
Typical Input Devices Monitored	Two-hand control
Type of Reset	Automatic
Feedback Monitoring	Yes
LED Displays	Green LEDs for: <ul style="list-style-type: none"> • K1 (safety relay 1) • K2 (safety relay 2)
Conformity to Standards	UL, CSA, BG (CE-compliant)
Stop Category	0
Safety Control Category Rating Per EN 954-1	4
Selected Features	<ul style="list-style-type: none"> • Plug-in screw terminals • Electronic fuse • Cross-short recognition • Automatic reset

Front View

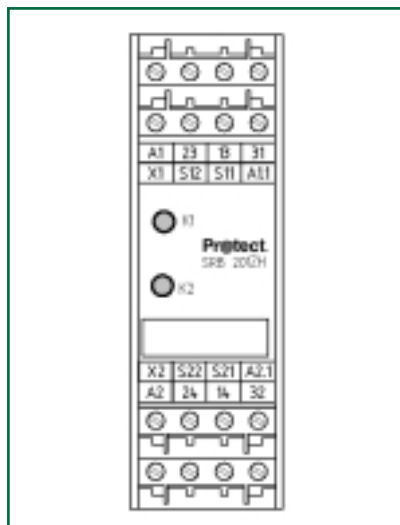

Available Models	
Model Number	Operating Input Voltage
SRB 201ZH	24 VDC

Two-Hand Control Safety Controller

Mechanical Specifications	
Dimensions (W x H x D)	22.5mm x 100mm x 121mm (0.9" x 3.9" x 4.75")
Ambient Operating Temperature Range	-25°C to +45°C (-13°F to +113°F)
Mechanical Life Expectancy	10 ⁷ switching cycles
Weight	200 gm
Mounting	DIN rail

Electrical Specifications	
Operating Voltage	24 VDC -15% / +20%, residual ripple max. 10%
Power Consumption	1.2 W (max.)
Fuse (Input Power)	Internal electronic fuse* F1, F2 : tripping current >.02 A F3 : tripping current >.06 A (Hybrid)
Fuse (Safety Outputs)	6 A Slow-blow (Recommended)
Switching Capacity (Safety Outputs)	230 VAC, 6 A Resistive (inductive with suitable suppressor circuit)
Switching Capacity (Auxiliary Contacts)	24 VDC, 2 A
Application Category	AC 15 / DC 13 : EN 60 947-5-1
Pick-up Delay	≤ 50 ms
Drop-out Delay	≤ 30 ms
Contact Type & Materials	AgSnO self cleaning, positively driven
Contact Resistance	100 mOhm (max. in new state)
Air Clearance & Creepage Distance	DIN VDE 0110-1 (04.97), 4 kV/2
Cable Connections	<ul style="list-style-type: none"> Plug-in self-lifting screw terminals for 13 to 20 AWG Stranded or multi-core with wire end ferrule
Terminal Labeling	DIN EN 50 005 / DIN 50 013

Typical Wiring Diagram

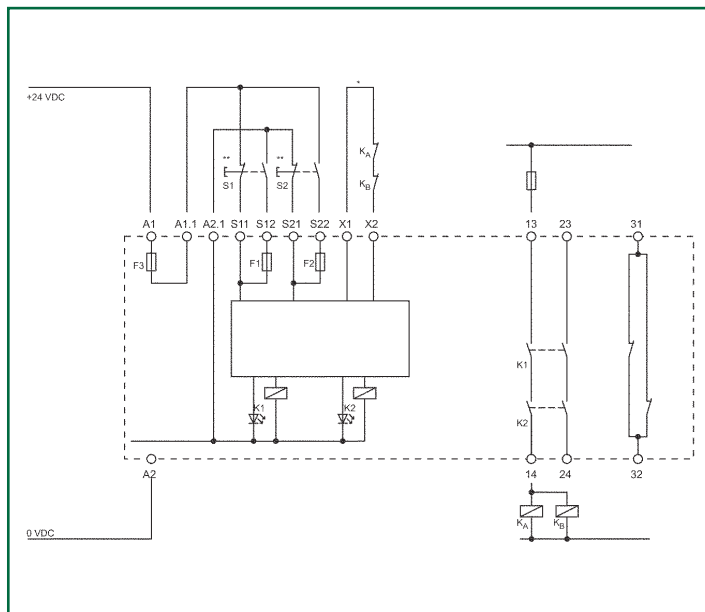

*Resets automatically after a short time-delay.

Terminal Connections

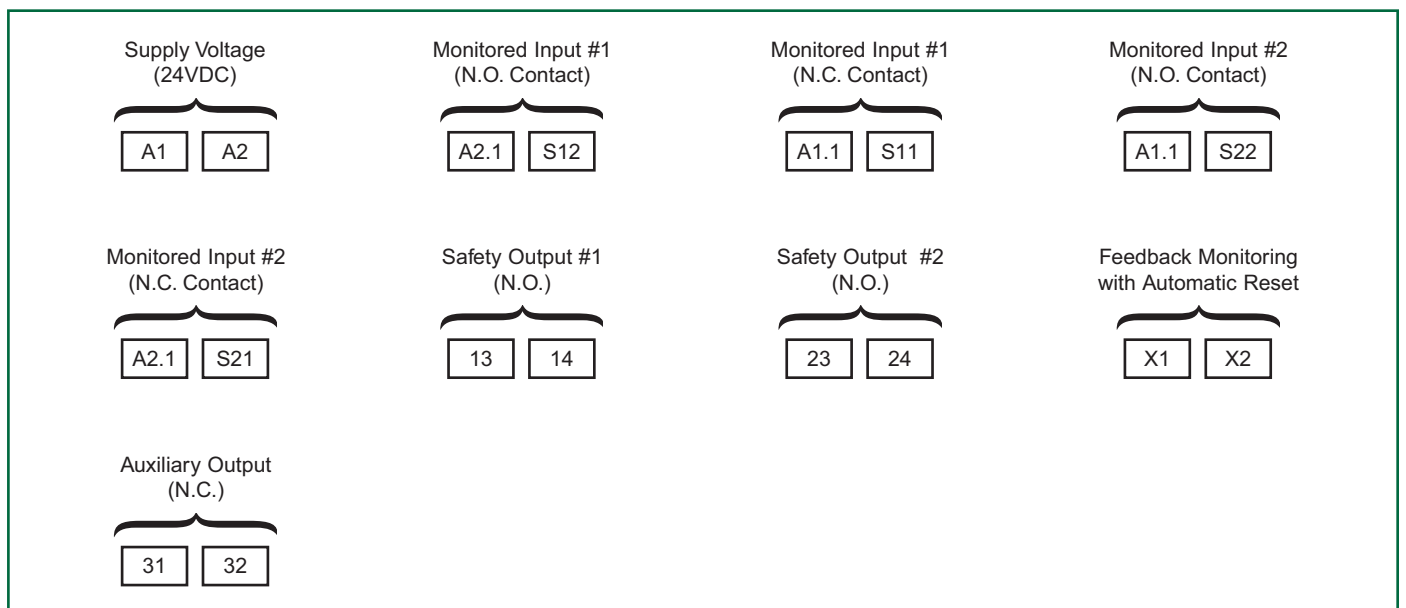

Series SRB 206 ST & SRB 206 SQ

General-Purpose Safety Controllers (for dry contact input monitoring)



Description

The Model SRB 206 ST/SQ family are “general purpose” units designed for use with safety devices having Normally-Closed (N.C.) dry contacts. Each is equipped for connection with up to six input devices such as E-stop push button and safety interlock switches. In addition it features user-selectable monitored-manual or automatic reset, six (non-safety) semiconductor outputs for signalling/annunciation, and two safety outputs. SRB 206 SQ and SRB 206 SQ-230 also feature cross-short recognition.

Front View

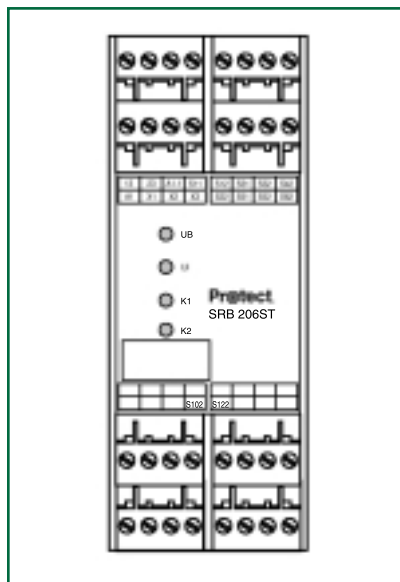

Technical Features	
Input Voltage	SRB 206 ST (SQ) 24 VAC / DC SRB 206 ST (SQ) - 230 V 48 - 230 V AC
# Discrete Input Devices Monitored	6 (Single or Dual-Channel)
Compatible Input Device Contact Configuration	N.C. (Dry Contacts)
Number & Type Safety Outputs	2 N.O. (Dry Contacts)
Number & Type Auxiliary (Non-Safety or Signalling Outputs)	6 - short circuit proof, PNP-type semiconductor Y1 - Y6 max 20mA
Typical Input Devices Monitored	<ul style="list-style-type: none"> E-stops (N.C.) Interlock switches (N.C.)
Type of Reset (Selectable)	<ul style="list-style-type: none"> Monitored-manual (24 VDC trailing edge) Automatic
Feedback Monitoring	Yes
LED Displays	Green LEDs for: <ul style="list-style-type: none"> K1 (safety relay 1) K2 (safety relay 2) Ui (voltage beyond internal fuse) Ub (voltage at input terminals)
Conformity to Standards	UL, CSA, BG (CE-compliant)
Stop Category	0
Safety Control Category Rating Per EN 954-1	3
Selected Features	<ul style="list-style-type: none"> Plug-in screw terminals Cross-short recognition (SRB 206 SQ models only) Up to 6 monitored devices Six auxiliary outputs Selectable monitored-manual or automatic reset

Available Models	
Model Number	Operating Input Voltage
SRB 206 ST	24V AC/DC
SRB 206 ST - 230V	48 - 230 VAC
SRB 206 SQ*	24V AC/DC
SRB 206 SQ-230*	48 - 230 VAC

*Feature cross-short recognition.

Series SRB 206 ST & SRB 206 SQ

General-Purpose Safety Controllers

Mechanical Specifications	
Dimensions (W x H x D)	45mm x 100mm x 121mm (1.77" x 3.9" x 4.75")
Ambient Operating Temperature Range	-25°C to +45°C (-13°F to +113°F)
Mechanical Life Expectancy	>10 ⁷ switching cycles
Weight	300 gm
Mounting	DIN rail

Electrical Specifications	
Operating Voltage	24 VDC -15% / +20%, residual ripple max. 10% 24 VAC -15% / +10%, 50/60 Hz 48 VAC-240VAC, 50/60 Hz
Power Consumption	3.6 W (max.), 3.6 VA
Fuse (Input Power)	
24 V	Internal electronic (hybrid) Fuse F1, Tripping current > 1 A (Resets after interruption of supply voltage)
230 V	Primary : Fuse (glass), tripping current > 0.5 A Secondary : Internal electronic fuse, tripping current > 0.12 A
Fuse (Safety Outputs)	6 A Slow-blow (Recommended)
Switching Capacity (Auxiliary Contacts)	24 VDC, 20 mA
Switching Capacity (Safety Outputs)	230 VAC, 6 A Resistive (inductive with suitable suppressor circuit)
Application Category	AC 15 / DC 13 : EN 60 947-5-1
Pick-up Delay	≤ 200 ms
Drop-out Delay	≤ 40 ms
Contact Type & Materials	AgCdO, self cleaning, positive-guided
Contact Resistance	100 mOhm (max. in new state)
Air Clearance & Creepage Distance	DIN VDE 0110-1 (04.97), 4 kV/2
Cable Connections	<ul style="list-style-type: none"> Self-lifting, plug-in screw terminals for 13 to 20 AWG Stranded or multi-core with wire end ferrule
Terminal Labeling	DIN EN 50 005 / DIN 50 013

Typical Wiring Diagram (shown with 1 input)

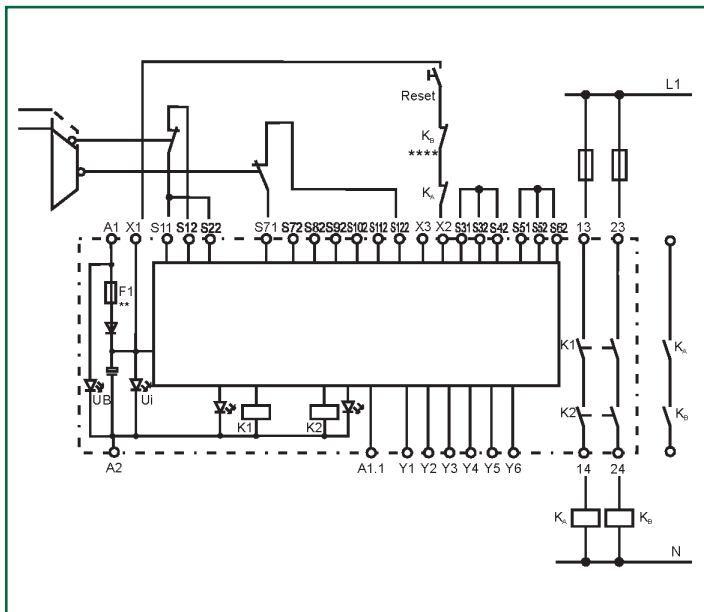

Terminal Connections (Model SRB 206 ST shown)

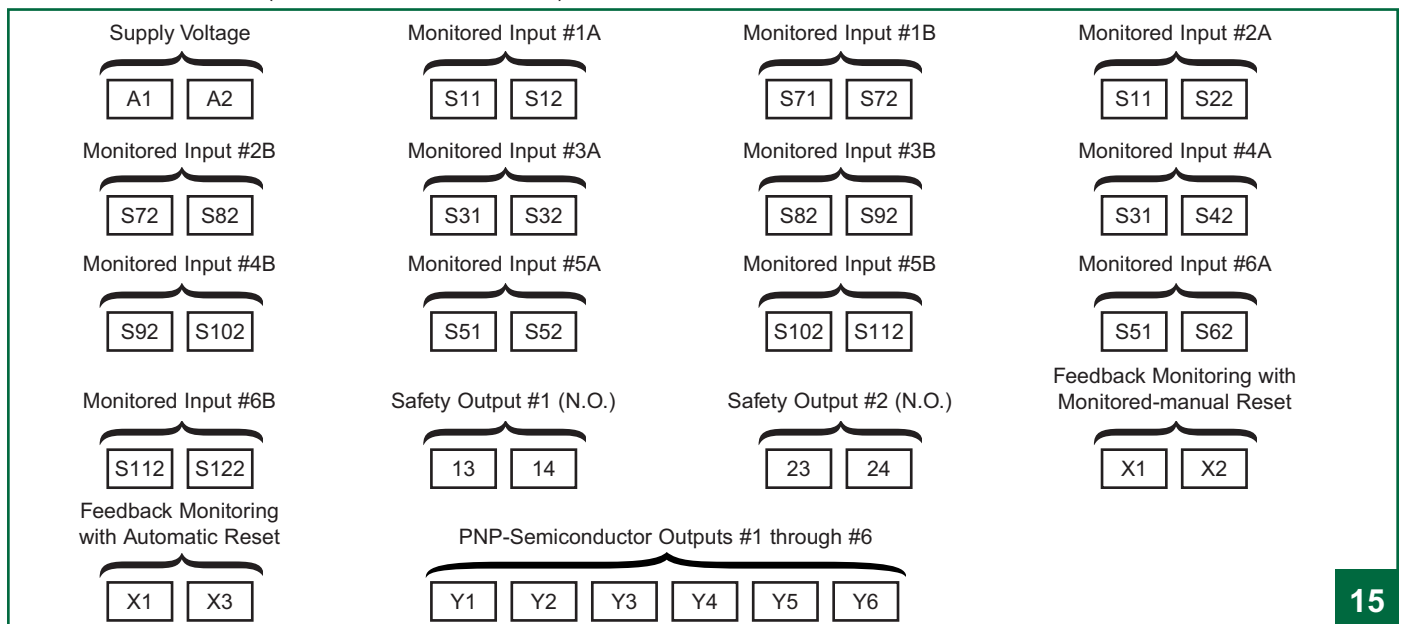

Series SRB 211 ST

General-Purpose Safety Controller (for dry contact and PNP-type input monitoring)



Description

The Model SRB 211 ST is a “general purpose” unit designed for use with safety devices having Normally-Closed (N.C.) dry contacts or PNP-type switching outputs. It is equipped for connection of one monitored input device in single- or dual-channel configuration. In addition it features user-selectable monitored-manual or automatic reset, stop category 0 & 1 safety outputs, and feedback monitoring of positive-guided controlled loads.

Front View

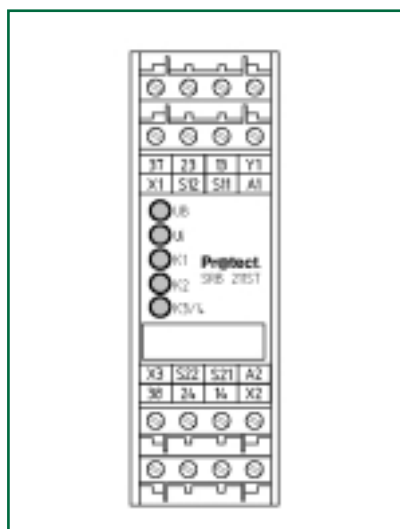

Technical Features

Input Voltage	24 V AC/DC
# Discrete Input Devices Monitored	1 (Single or Dual-Channel)
Compatible Input Device Contact Configuration	N.C. (Dry Contacts) or PNP-switching
Number & Type Safety Outputs	3 N.O. (1 delayed : 1-30 sec.) (dry contacts)
Number & Type Auxiliary (Non-Safety or Signalling Outputs)	PNP
Typical Input Devices Monitored	<ul style="list-style-type: none"> • E-stops (N.C.) • Interlock switches (N.C.) • Devices with PNP semiconductor outputs
Type of Reset (Selectable)	<ul style="list-style-type: none"> • Monitored-manual (24 VDC trailing edge) • Automatic
Feedback Monitoring	Yes
LED Displays	Green LEDs for: <ul style="list-style-type: none"> • K1 (safety relay 1) • K2 (safety relay 2) • K3/4 (safety relay 3 & 4) • U_i (voltage beyond internal fuse) • U_b (voltage at input terminals)
Conformity to Standards	UL, CSA, BG (CE-compliant)
Stop Category	0 (2 safety outputs) 1 (1 safety output)
Safety Control Category Rating Per EN 954-1	4
Selected Features	<ul style="list-style-type: none"> • Plug-in screw terminals • Cross-short recognition • Stop category 0 & 1 safety outputs • Selectable monitored-manual or automatic reset • Hybrid fuse • Feedback monitoring

Available Models

Model Number	Operating Voltage
SRB 211 ST	24 V AC/DC

General-Purpose Safety Controller

Mechanical Specifications	
Dimensions (W x H x D)	22.5mm x 100mm x 121mm (0.9" x 3.9" x 4.75")
Ambient Operating Temperature Range	-25°C to +45°C (-13°F to +113°F)
Mechanical Life Expectancy	>10 ⁷ switching cycles
Weight	255 gm
Mounting	DIN rail

Electrical Specifications	
Operating Voltage	24 VDC -15% / +20%, residual ripple max. 10% 24 VAC -15% / +10%, 50/60 Hz
Power Consumption	5.1 W, 5.7 VA (max.), plus signaling output Y1
Fuse (Input Power)	Internal electronic (hybrid) Fuse F1, Tripping current > 1 A (Resets after interruption of supply voltage)
Fuse (Safety Outputs)	4 A Slow-blow (Recommended)
Switching Capacity (Safety Outputs)	230 VAC, 4 A Resistive (inductive with suitable suppressor circuit)
Switching Capacity (Auxiliary Contacts)	24 VDC 100mA
Application Category	AC 15 / DC 13 : EN 60 947-5-1
Pick-up Delay	≤ 40 ms
Drop-out Delay	≤ 40 ms
Contact Type & Materials	AgSnO, self cleaning, positive-guided
Contact Resistance	100 mOhm (max. in new state)
Air Clearance & Creepage Distance	DIN VDE 0110-1 (04.97), 4 kV/2
Cable Connections	<ul style="list-style-type: none"> • Plug-in, self-lifting, screw terminals for 13 to 20 AWG • Stranded or multi-core with wire end ferrule
Terminal Labeling	DIN EN 50 005 / DIN 50 013

Typical Wiring Diagram

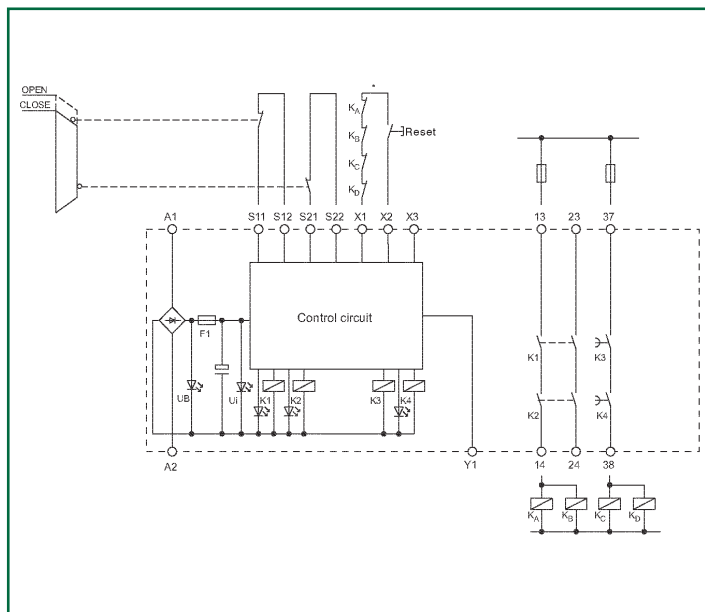

Terminal Connections

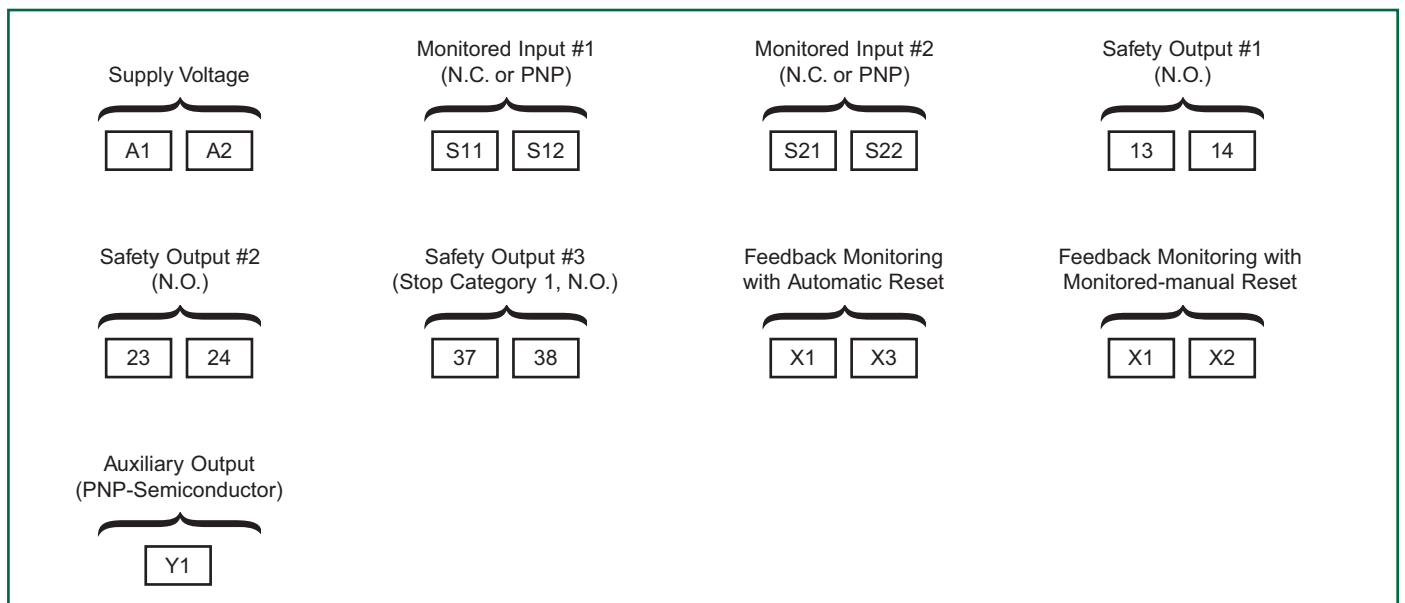

Series SRB 301 LC & SRB 301 LCI

General-Purpose Safety Controller (for dry contact and PNP-type input monitoring)

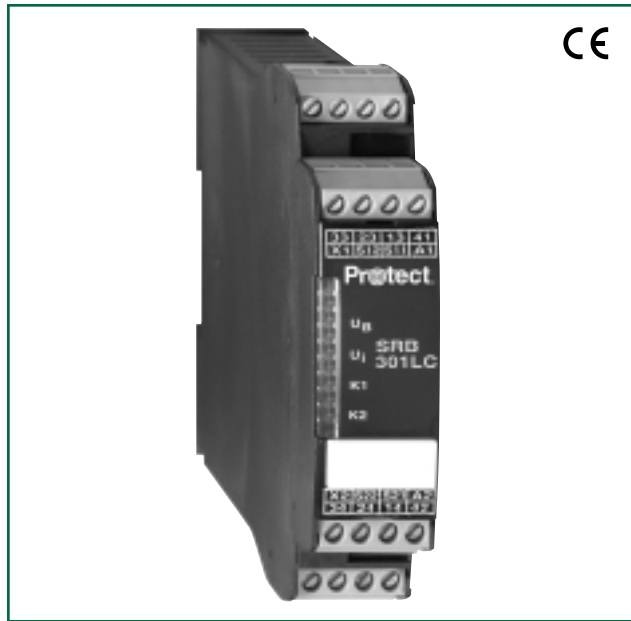

Description

The Model SRB 301 LC is a lower cost “general-purpose” unit designed for use with safety devices having Normally-Closed (N.C.) or PNP-type switching outputs. It is equipped for connection of one input device in single- or dual-channel configuration. In addition it features feedback monitoring of positive-guided controlled loads, automatic or manual reset and optional cross-short recognition.

Front View

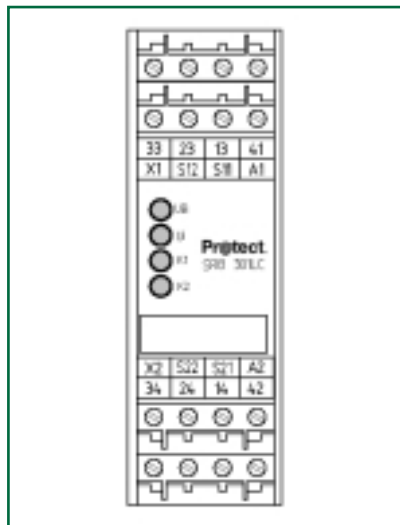

Technical Features

Input Voltage	24 V AC/DC
# Discrete Input Devices Monitored	1 (Single or Dual-Channel)
Monitored Contact Configuration	N.C. (Dry Contacts) or PNP-switching
Number & Type Safety Outputs	3 N.O. (Dry Contacts)
Number & Type Auxiliary (Non-Safety or Signalling Output)	1 N.C. (Dry Contacts)
Typical Input Devices Monitored	<ul style="list-style-type: none"> • E-stops (N.C.) • Interlock switches (N.C.) • Devices with PNP semi-conductor outputs
Type of Reset (Selectable)	<ul style="list-style-type: none"> • Manual (24 V Leading Edge) • Automatic
Feedback Monitoring	Yes
LED Displays	Green LEDs for: <ul style="list-style-type: none"> • K1 (safety relay 1) • K2 (safety relay 2) • U_i (voltage beyond internal fuse) • U_B (voltage at input terminals)
Conformity to Standards	UL, CSA, BG (CE-compliant)
Stop Category	0
Safety Control Category Rating Per EN 954-1	4
Selected Features	<ul style="list-style-type: none"> • Cross-short recognition (Field-wired option) • Screw terminals (LC) • Detachable terminals (LCI) • Feedback monitoring • Electronic fuse (LCI) • Glass fuse (LC)

Available Models

Model Number	Operating Voltage
SRB 301 LC	24 V AC/DC
SRB 301 LCI	24 V AC/DC

Series SRB 301 LC & SRB 301 LCI

General-Purpose Safety Controller

Mechanical Specifications	
Dimensions (W x H x D)	22.5mm x 100mm x 121mm (0.9" x 3.9" x 4.75")
Ambient Operating Temperature Range	-25°C to +45°C (-13°F to +113°F)
Mechanical Life Expectancy	>10 ⁷ switching cycles
Weight	230 gm (0.5 lbs.)
Mounting	DIN rail (35mm)

Electrical Specifications	
Operating Voltage	24 VDC -15% / +20%, residual ripple max. 10% 24 VAC -15% / +10%, 50/60 Hz
Power Consumption	1.7 W (max.), 1.9 VA
Fuse (Input Power)	<ul style="list-style-type: none"> Internal glass fuse F1: T 1.25 A (SRB 301 LC) Internal electronic fuse* (SRB 301 LCI)
Fuse (Safety Outputs)	6 A Slow-blow (Recommended)
Switching Capacity (Safety Outputs)	230 VAC, 6 A Resistive (inductive with suitable suppressor circuit)
Switching Capacity (Auxiliary Contacts)	24 VDC, 2 A
Application Category	AC 15 / DC 13, EN 60 947-5-1
Pick-up Delay	≤ 30 ms
Drop-out Delay	≤ 50 ms
Contact Type & Materials	AgSnO, self cleaning, positive-guided
Contact Resistance	100 mOhm (max. in new state)
Air Clearance & Creepage Distance	DIN VDE 0110-1 (04.97), 4 kV/2
Cable Connections	<ul style="list-style-type: none"> Self-lifting, screw terminals for 13 to 20 AWG Stranded or multi-core with wire end ferrule
Terminal Labeling	DIN EN 50 005 / DIN 50 013

Typical Wiring Diagram

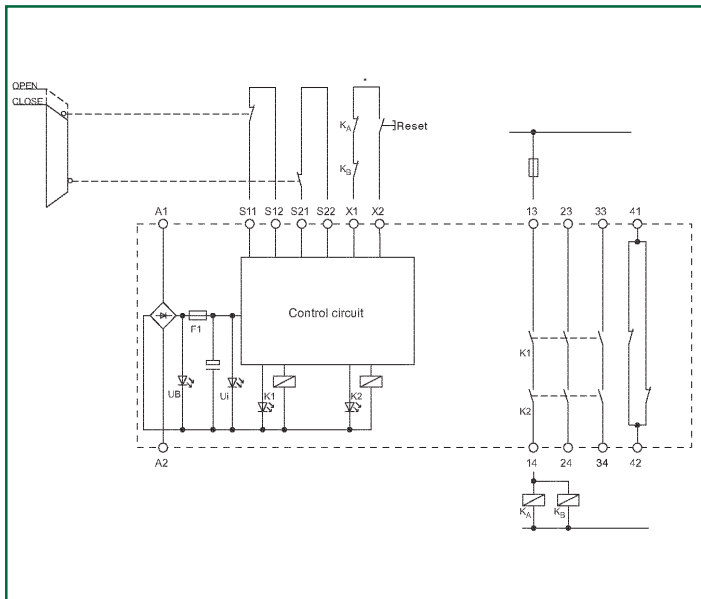

*Resets automatically after a short time-delay.

Terminal Connections

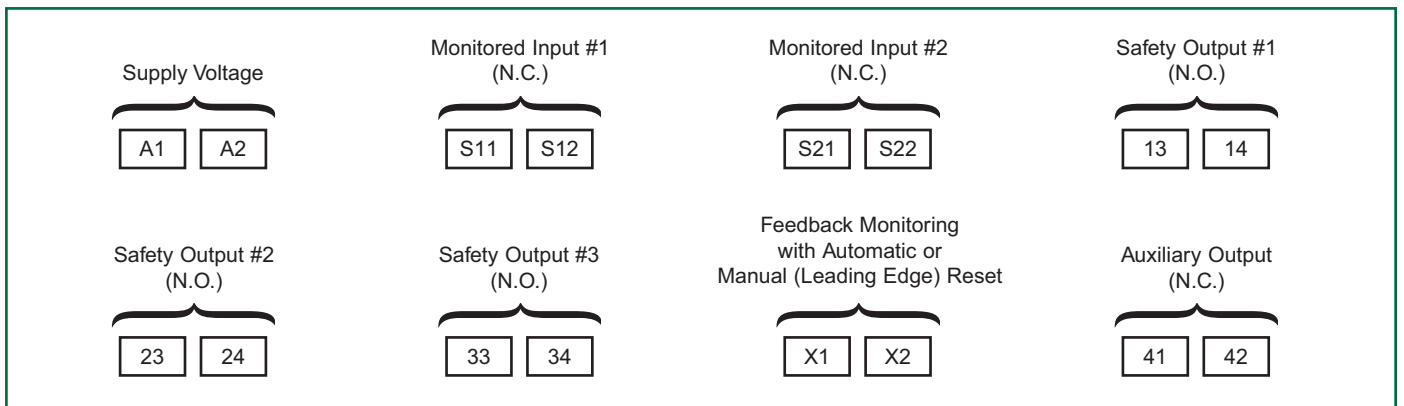

Series SRB 301 ST, SRB 301 ST - 230V & SRB 301 SQ - 230V

General-Purpose Safety Controllers (for dry contact and PNP-type input monitoring)



Model SRB 301 ST shown.

Description

The above “general-purpose” safety controllers are designed for use with safety devices having Normally-Closed (N.C.) or PNP-type switching outputs. Each is equipped for connection of one input device in single- or dual-channel configuration. In addition they feature plug-in screw terminals, user-selectable monitored-manual or automatic reset, feedback monitoring of positive-guided controlled loads and cross-short recognition (on selected models).

Front View

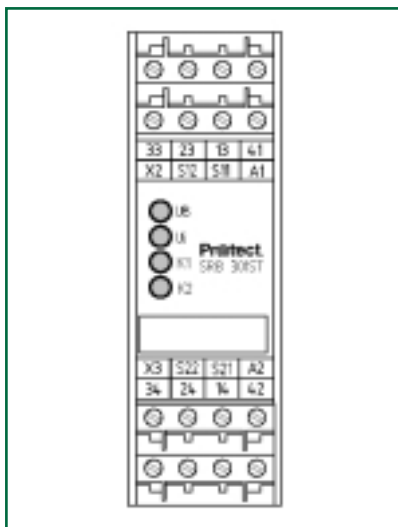

Model SRB 301 ST shown.

Technical Features

Input Voltage	
SRB 301 ST	24 VAC / DC
SRB 301 ST - 230 V	48 - 230 V AC
SRB 301 SQ - 230 V	48 - 230 V AC
# Discrete Input Devices Monitored	1 (Single or Dual-Channel)
Monitored Contact Configuration	N.C. (Dry Contacts)
Number & Type Safety Outputs	3 N.O. (Dry Contacts)
Number & Type Auxiliary (Non-Safety or Signalling Output)	1 N.C. (Dry Contacts)
Typical Input Devices Monitored	<ul style="list-style-type: none"> E-stops (N.C.) Interlock switches (N.C.) Devices with PNP semiconductor outputs (SRB 301 ST only)
Type of Reset (Selectable)	<ul style="list-style-type: none"> Monitored-manual (24 VDC trailing edge) Automatic
Feedback Monitoring	Yes
LED Displays	Green LEDs for: <ul style="list-style-type: none"> K1 (safety relay 1) K2 (safety relay 2) Ui (voltage beyond internal fuse) U_B (voltage at input terminals, SRB 301 ST only)
Conformity to Standards	UL, CSA, BG (CE-compliant)
Stop Category	0
Safety Control Category Rating Per EN 954-1	4
Type Fuse	Hybrid
Selected Features	<ul style="list-style-type: none"> Cross-short recognition (SRB 301ST 24 VAC / DC & SRB 301 SQ only) Plug-in screw terminals Selectable monitored-manual or automatic reset Feedback monitoring

Available Models

Model Number	Operating Voltage
SRB 301 ST*	24 V AC/DC
SRB 301 ST - 230 V	48 V AC - 240 V A/C
SRB 301 SQ - 230 V*	48 V AC - 240 V A/C

*Feature cross-short recognition.

Series SRB 301 ST, SRB 301 ST - 230V & SRB 301 SQ - 230V

General-Purpose Safety Controllers

Mechanical Specifications	
Dimensions (W x H x D)	22.5mm x 100mm x 121mm (0.9" x 3.9" x 4.75")
Ambient Operating Temperature Range	-25°C to +45°C (-13°F to +113°F)
Mechanical Life Expectancy	>10 ⁷ switching cycles
Weight	
SRB 301 ST	240 gm (0.5 lbs.)
SRB 301 ST - 230V	250 gm
Mounting	DIN rail (35mm)

Electrical Specifications	
Operating Voltage	
SRB 301 ST	24 VDC -15% / +20%, residual ripple max. 10%
SRB 301 ST (SQ) - 230V	24 VAC -15% / +10%, 50/60 Hz 48 VAC - 240 VAC, 50/60 Hz
Power Consumption	
SRB 301 ST	2.4 W (max.), 3.8 VA
SRB 301 ST (SQ) - 230V	2.8 VA
Fuse (Input Power)	
24 V	Internal electronic (hybrid) Fuse F1, Tripping current > 0.6 A (Resets after interruption of supply voltage)
230 V	F1 : glass bulb, tripping current 0.5 A Secondary : electronic fuse, tripping current 0.12 A
Fuse (Safety Outputs)	6 A Slow-blow (Recommended)
Switching Capacity (Safety Outputs)	230 VAC, 6 A Resistive (inductive with suitable surge suppressor)
Switching Capacity (Auxiliary Contacts)	24 VDC, 2 A
Application Category	AC 15 / DC 13, EN 60 947-5-1
Pick-up Delay	
SRB 301 ST	≤ 200 ms
SRB 301 ST (SQ) - 230V	≤ 30 ms
Drop-out Delay	
SRB 301 ST	≤ 20 ms
SRB 301 ST (SQ) - 230V	≤ 30 ms
Contact Type & Materials	AgSnO, self cleaning, positive-guided
Contact Resistance	100 mOhm (max. in new state)
Air Clearance & Creepage Distance	DIN VDE 0110-1 (04.97), 4 kV/2
Cable Connections	<ul style="list-style-type: none"> Self-lifting, plug-in screw terminals for 13 to 20 AWG Stranded or multi-core with wire end ferrule
Terminal Labeling	DIN EN 50 005 / DIN 50 013

Typical Wiring Diagram

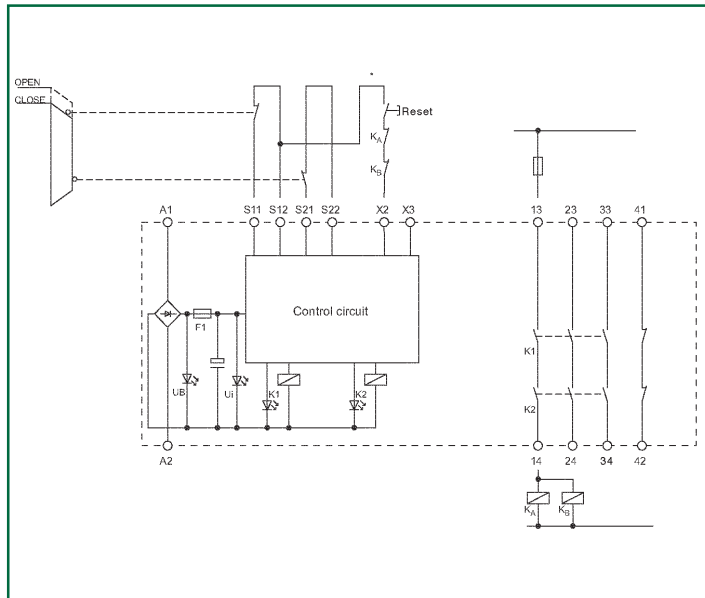

Terminal Connections (Model SRB 301 ST shown)

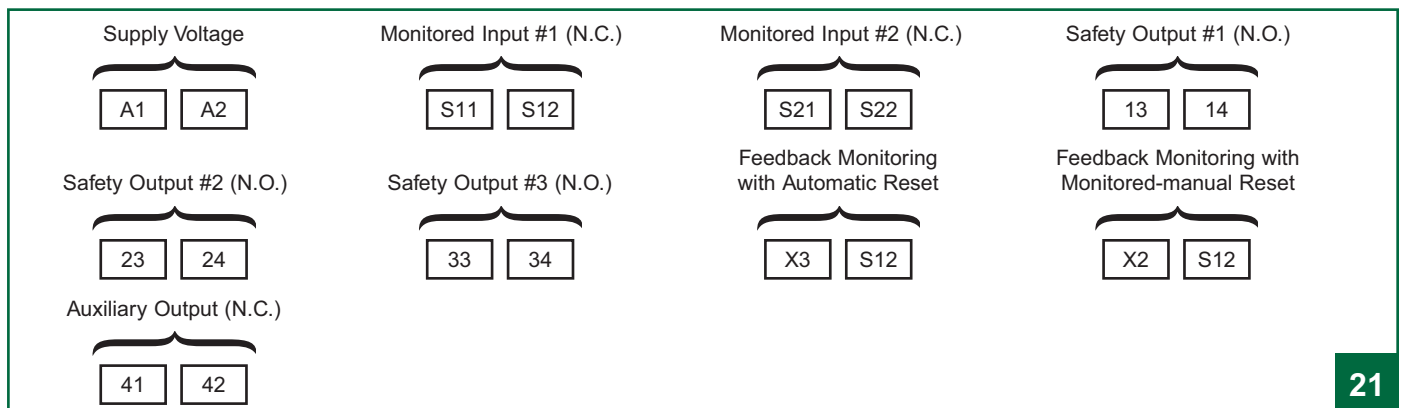

Series SRB 202 C & SRB 400 C

Differentiated-Input Controllers



Description

The Series SRB202C and SRB400C are (general purpose) units designed for use with safety devices having two Normally-Closed (N.C.) and/or one Normally-Open (N.O.) and one Normally-Closed (N.C.) dry contacts. Uniquely, they provide for differentiated switching of the safety outputs depending on the input that is actuated.

For example, actuating an E-Stop as Input #1 would disable all of the unit's safety outputs. Conversely, actuation of Input #2 (e.g., a safety guard interlock switch) would only disable half of the available safety outputs (safety output #2 on SRB202C units and safety outputs #3 & #4 on SRB400C units).

Thus this functionality, which would normally require two discrete safety controllers, can be achieved with a single unit (controller).

Front View

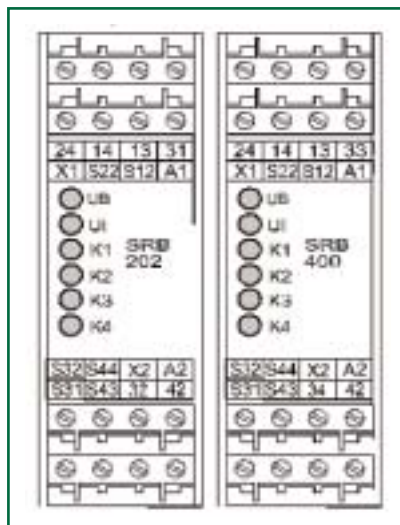

Technical Features

Input Voltage	24 VDC
# Discrete Input Devices Monitored	2
Compatible Input Device Contact Configuration	Input #1: 2 N.C. (Dry contacts) Input #2: 2 N.C. or 1 N.O./1 N.C.
Number & Type Safety Outputs	2 N.O. (SRB202 models) 4 N.O. (SRB400 models)
Number & Type Auxiliary (Non-Safety or Signalling Outputs)	SRB202: 2 N.C. SRB400: None
Typical Input Devices Monitored	<ul style="list-style-type: none"> E-stops (N.C.) Interlock switches (N.C.)
Type of Reset (Depends on model)	<ul style="list-style-type: none"> Monitored-manual (24 VDC trailing edge) Automatic or Manual
Feedback Monitoring	Yes
LED Displays	Green LEDs for: <ul style="list-style-type: none"> K1 (safety relay 1) K2 (safety relay 2) K3 (safety relay 3) K4 (safety relay 4) Ui (voltage beyond internal fuse) Ub (voltage at input terminals)
Conformity to Standards	UL, CSA, BG (CE-compliant)
Stop Category	0
Safety Control Category Rating Per EN 954-1	4
Selected Features	<ul style="list-style-type: none"> Plug-in screw terminals Cross-short recognition ("Q" models only) Electronic fuse Feedback monitoring

Selection Chart

Model #	Outputs		Input #1			Input #2	
	Safety	Aux	Contacts	Reset	Cross-short	Contacts	Reset
SRB202CA	2	2	2 N.C.	Auto or Manual	No	1 N.O./1 N.C.*	Auto or Manual
SRB202CS	2	2	2 N.C.		No	2 N.C.	
SRB202CA/Q	2	2	2 N.C.	Monitored-manual	Yes	1 N.O./1 N.C.*	
SRB202CA/T	2	2	2 N.C.		No	1 N.O./1 N.C.*	
SRB202CS/T	2	2	2 N.C.		No	2 N.C.	
SRB202CA/QT	2	2	2 N.C.		Yes	1 N.O./1 N.C.*	
SRB400CA	4	0	2 N.C.	Auto or Manual	No	1 N.O./1 N.C.*	Auto or Manual
SRB400CS	4	0	2 N.C.		No	2 N.C.	
SRB400CA/Q	4	0	2 N.C.	Monitored-manual	Yes	1 N.O./1 N.C.*	
SRB400CA/T	4	0	2 N.C.		No	1 N.O./1 N.C.*	
SRB400CS/T	4	0	2 N.C.		No	2 N.C.	
SRB400CA/QT	4	0	2 N.C.		Yes	1 N.O./1 N.C.*	

*Suitable for use with BNS coded-magnet switches.

Series SRB 202 C & SRB 400 C

Differentiated-Input Controllers

Mechanical Specifications

Dimensions (W x H x D)	22.5mm x 100mm x 121mm (0.9" x 3.9" x 4.75")
Ambient Operating Temperature Range	-25°C to +45°C (-13°F to +113°F)
Mechanical Life Expectancy	>10 ⁷ switching cycles
Weight	235 gm
Mounting	DIN rail

Electrical Specifications

Operating Voltage	24 VDC -15% / +20%, residual ripple max. 10%
Power Consumption	4.4 W
Fuse (Input Power)	Internal electronic fuse* F1, Tripping current > 1 A
Fuse (Safety Outputs)	6 A Slow-blow (Recommended)
Switching Capacity (Safety Outputs)	230 VAC, 6 A Resistive (inductive with suitable suppressor circuit)
Switching Capacity (Auxiliary Contacts)	24 VDC 100mA
Application Category	AC 15 / DC 13 : EN 60 947-5-1
Pick-up Delay	≤ 40 ms
Drop-out Delay	≤ 50 ms
Contact Type & Materials	AgSnO, self cleaning, positive-guided
Contact Resistance	100 mOhm (max. in new state)
Air Clearance & Creepage Distance	DIN VDE 0110-1 (04.97), 4 kV/2
Cable Connections	<ul style="list-style-type: none"> • Plug-in, self-lifting, screw terminals for 13 to 20 AWG • Stranded or multi-core with wire end ferrule
Terminal Labeling	DIN EN 50 005 / DIN 50 013

Typical Wiring Diagram

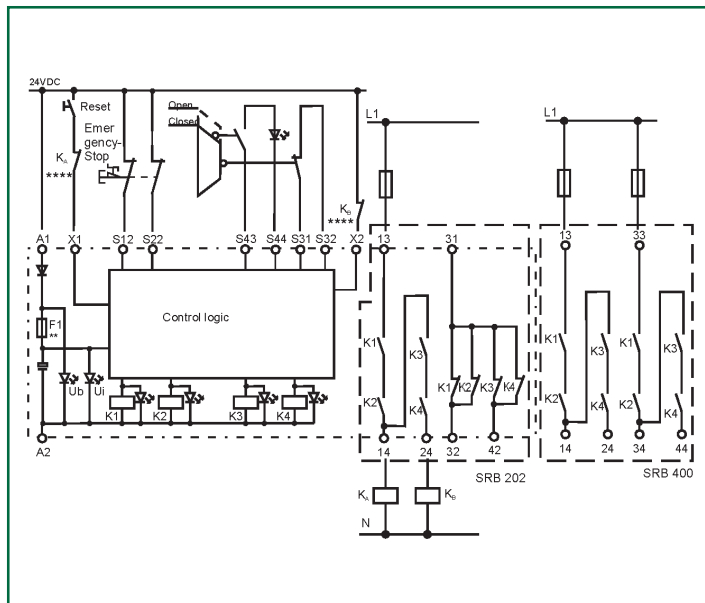

*Resets automatically after a short time-delay.

Terminal Connections

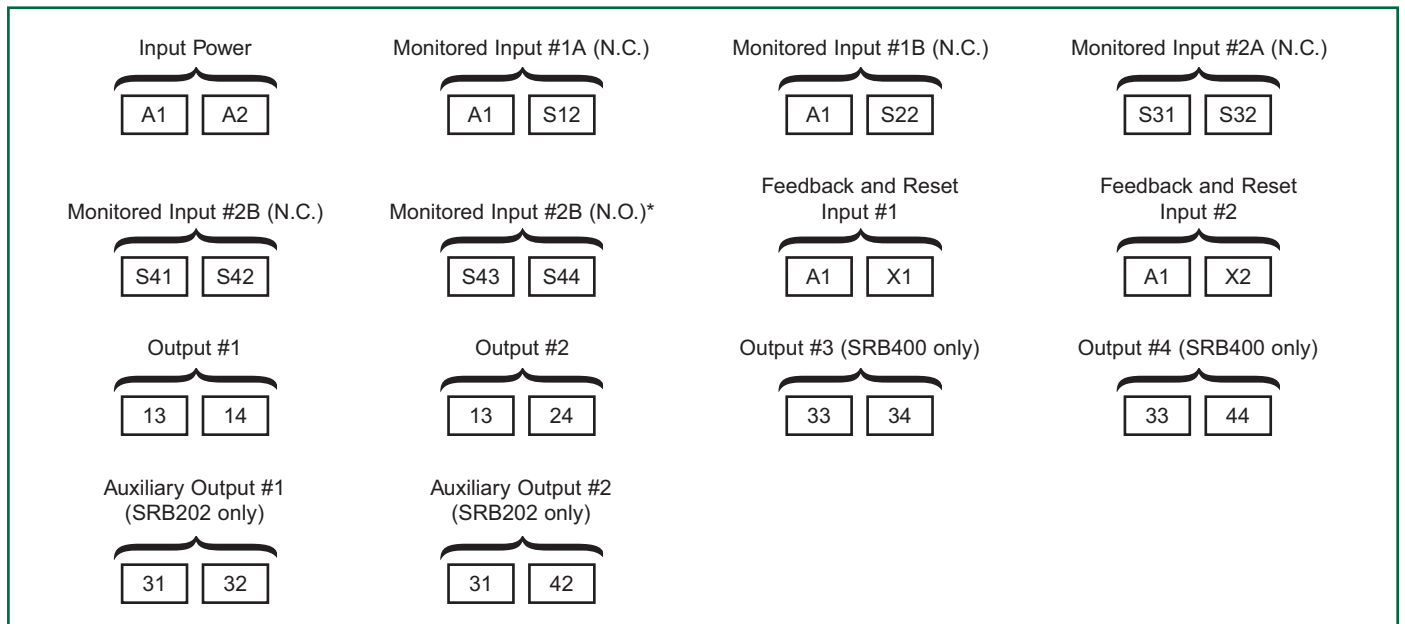

*For models having 1 N.O./1 N.C. contacts on Input #2.

Series SRB 402 EM

Safety Output Expansion Module



Technical Features	
Input Voltage	24 V AC/DC
Number & Type Safety Outputs	4 N.O. (Dry Contacts)
Number & Type Auxiliary (Non-Safety or Signalling Outputs)	2 N.C. (Dry Contacts)
LED Displays	Green LEDs for: • K1/K2 (safety relay 1 & 2)
Conformity to Standards	UL, CSA, BG (CE-compliant)
Stop Category	0
Safety Control Category Rating Per EN 954-1	Function of Master Safety Controller (mounted in same control cabinet)
Selected Features	<ul style="list-style-type: none"> • Plug-in screw terminals • Compatible with all SRB PROTECTSM Series models

Description

The Model SRB 402 EM is designed for use as an accessory for SCHMERSAL's PROTECTSM Series safety controllers. It provides additional safety (enabling) outputs where required to satisfy the system control requirements.

Available Models	
Model Number	Operating Voltage
SRB 402 EM	24 V AC/DC

Front View

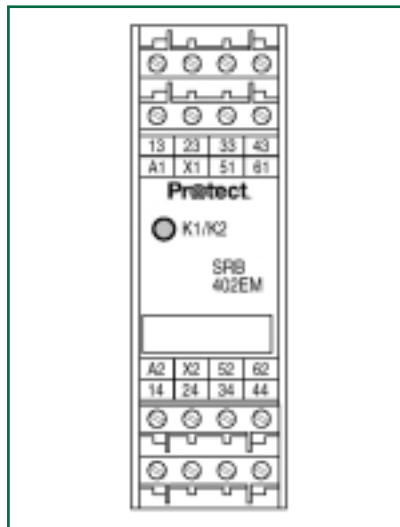

Safety Output Expansion Module

Mechanical Specifications	
Dimensions (W x H x D)	22.5mm x 90mm x 121mm (0.9" x 3.54" x 4.75")
Ambient Operating Temperature Range	-25°C to +45°C (-13°F to +113°F)
Mechanical Life Expectancy	>10 ⁷ switching cycles
Weight	215 gm (0.47 lbs.)
Mounting	DIN rail

Electrical Specifications	
Operating Voltage	24 VDC -15% / +20%, residual ripple max. 10% 24 VAC -15% / +10%, 50/60 Hz
Power Consumption	1.0 VA (max.)
Fuse (Input Power)	Glass fuse F1 : 1.0 A / 250 V (Slow-blow)
Fuse (Safety Outputs)	6 A Slow-blow (Recommended)
Switching Capacity (Safety Outputs)	230 VAC, 6 A Resistive (inductive with suitable supressor)
Switching Capacity (Auxiliary Contacts)	24 VDC, 2 A
Application Category	AC 15 / DC 13, DIN VDE 660 Teil 200
Pick-up Delay	≤ 30 ms
Drop-out Delay	≤ 35 ms
Contact Type & Materials	AgSnO, self cleaning, positive-guided
Contact Resistance	100 mOhm (max. in new state)
Air Clearance & Creepage Distance	DIN VDE 0110-1 (04.97), 4 kV/2
Cable Connections	<ul style="list-style-type: none"> • Self-lifting, screw terminals for 13 to 24 AWG • Stranded or multi-core with wire end ferrule
Terminal Labeling	DIN EN 50 005 / DIN 50 013

Typical Wiring Diagram

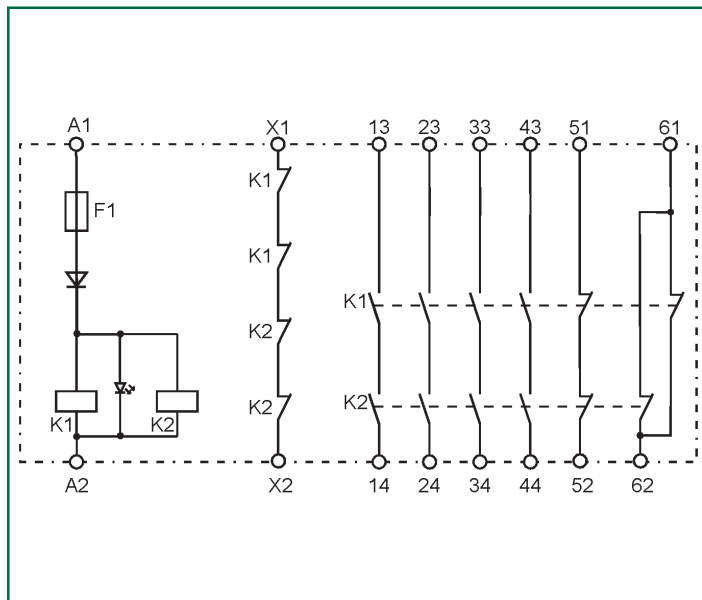

Terminal Connections

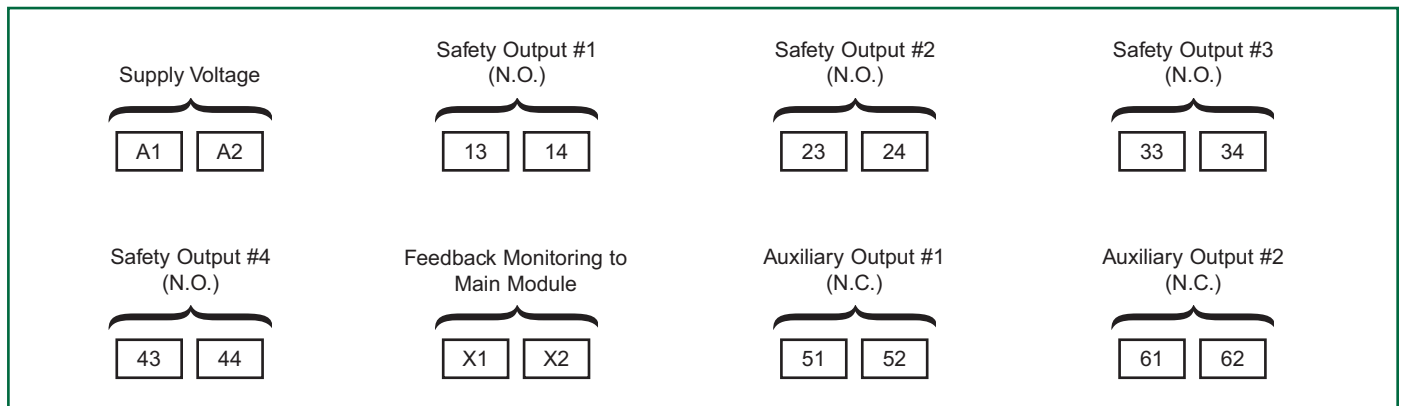

SAFETY CONTROLLER FAQs

1

What are “safety controllers” and what are their functions?

Safety controllers (such as SCHMERSAL's SRB Series) are connected between machine guarding interlock/E-Stop switches and the machine's stop control elements (such as a motor contactor or control relay).

These controllers contain dual, self-checking safety system monitoring circuits and positive-guided output relays. Each is designed to monitor faults in the safety system's interlock/E-Stop switches, the safety circuit interconnection wiring, and their own internal monitoring circuits and output relays.

Detection of a fault in the machine's safety circuit or of an open machine guard, disables the module's output signal(s) facilitating machine stoppage, and/or prevents the restarting of the machine until the fault has been corrected.

In addition to detecting open guards and/or actuated E-Stop switches, safety controllers are capable of detecting the following types of safety system faults:

- Guard monitoring switch/sensor failure
- “Open-circuit” in interconnection wiring
- “Short-circuit” in interconnection wiring
- “Short-to-ground” in interconnection wiring
- Cross-short between channels
- Welded contact in controlled output device (such as positive-guided motor contactor)
- Failure of safety controller's positive-guided relay(s)
- Fault in safety system monitoring circuit
- Insufficient operating voltage.

Some microprocessor-based safety controllers, such as SCHMERSAL'S AES Series (for use with coded-magnet sensors), also feature integrated system diagnostics with visual LED outputs which indicates fault type and location — thus minimizing machine downtime.

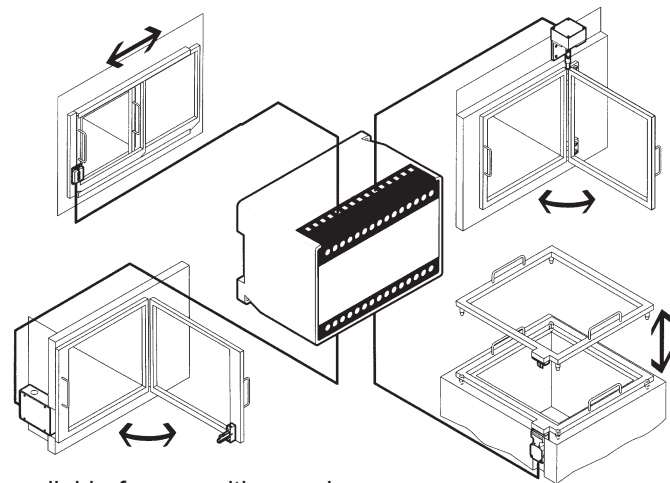
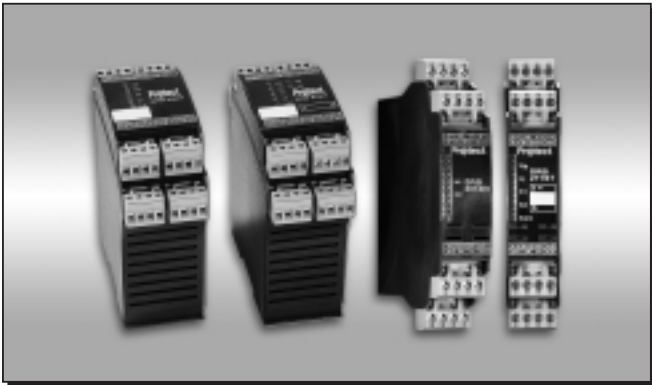

Safety controllers detect and locate system faults. Units are available for use with guard interlock switches, coded-magnet sensors, safety edges, light curtains, E-stops and emergency cable-pull switches to satisfy a broad range of application requirements.

2

Why should safety controllers be used with safety interlocks/E-Stops?

Safety controllers increase the reliability of the machine guarding safety system. Their ability to detect safety cir-

cuit faults, and shut down the machine until the fault is corrected, greatly heighten the safety level.

3

What is the difference between a single and dual-channel safety controller, and when should each be used?

A single-channel safety controller is capable of accepting only one (normally-closed) input. When used in safety circuits they are unable to detect a short-circuit failure in the interconnection wiring, or a failure of the monitored input to change state.

A dual-channel safety controller is capable of accepting two inputs; one to each of its two, redundant self-monitoring safety circuits. When used in safety circuits they are typically capable of detecting interconnection wiring faults (such as short-circuits, open circuits, and ground faults) or a failure of one of the monitored input(s) to

change state. As such they provide a higher level of safety than single-channel units.

Single-channel safety controllers are suitable for relatively low levels of risk assessment (e.g. EN 954-1 Safety Categories B, 1 and 2). Dual-channel units are appropriate when designing “control reliable” safety systems — that is, systems in which a single component failure will not prevent normal machine stopping action from taking place, but will prevent a successive machine cycle from being initiated.

4

How do I decide which safety controller to use?

Safety controller selection is usually based on:

- (1) the type of inputs being monitored (e.g. E-Stops, interlock switches, light curtains, coded-magnet sensors, et al).
- (2) the number of inputs being monitored.
- (3) the number and type of outputs required from the safety controller (e.g. number of parallel outputs from the module’s positive-guided relays and the number of auxiliary/signaling outputs).
- (4) the need/desire to monitor the integrity of the positive-guided contacts in the controlled output device (e.g. motor contactor, control relay, et al).
- (5) the level of safety desired (this is usually determined by a structured risk assessment).

These application parameters will normally narrow, and simplify, the choice of safety controller to one or two units.

5

When is it necessary to design a safety system to satisfy the requirements of EN 954-1 Category 4?

Category 4 safety requirements are usually associated with extremely high-risk applications. Consequently the safety system needed to satisfy these conditions can be quite complex and costly.

Since general machine design practice respects classic safety hierarchy, most extremely high-risk hazards — that is:

- (a) those which the operator cannot avoid
- (b) those in which the operator is exposed frequently or continuously, and
- (c) those which could result in serious injury, amputation or death

are designed-out during machine development or are guarded against (if they cannot be designed-out).

Consequently for most applications it is generally not necessary to incur the cost/complexity of Category 4 safety system design. Many low-risk situations can be satisfied by safety systems that meet the requirements of Category B, 1 or 2 as defined by EN 954-1.

In most higher-risk situations, a suitable safety system (and one which meets ANSI’s requirement for “control reliability”) can be achieved with a system designed to meet the Category 3 requirements of EN 954-1.

When needed, Category 4 requirements can be satisfied by proper selection from SCHMERSAL’s wide range of CE-compliant safety interlocks and related safety controllers.

SELECTED MACHINE SAFEGUARDING TERMINOLOGY

Authorized Output: an output from a safety controller's positive-guided relays (used to "authorize" or "enable" a machine's start circuit when safety system conditions exist). Also known as "safety output."

Automatic Reset: a safety controller reset circuit that automatically resets the safety controller when safe system conditions (no system faults) exist. A manual reset button is optional.

Auxiliary output: a non-safety related contact closure or semiconductor output primarily used for signaling component or system status to a PLC, audible alarm or visual indicator (such as a stack light). Also called a "signaling contact" or "auxiliary monitoring contact".

ANSI (American National Standards Institute): an association of industry representatives who, working together, develop safety and other technical standards.

Auxiliary monitoring contact: See "auxiliary output".

BG (Berufsgenossenschaft): an independent German insurance agency whose legislative arm recommends industry safety practices. One of many "notified bodies" authorized to certify that safety products comply with all relevant standards.



CE (Conformité Européenne) mark: a symbol (CE) applied to finished products and machinery indicating it meets all applicable European Directives. For electrical and electronic "finished products", such as a safety relay module, these include the Low Voltage Directive and, where relevant, the Electromagnetic Compatibility (EMC) Directive.



Coded-Magnet Sensor: a two-piece position sensor consisting of an array of reed switches and a multiple magnet array-actuating element. Such devices will only deliver an output signal when the reed switch element is in the presence of a matched, multiple-magnetic field array. Coded-magnet sensors cannot be actuated using a simple magnet. Hence they are far more difficult to defeat/bypass than a simple magnetic switch or proximity sensor.

Control Reliability: A term applied to safety devices or systems which are designed constructed and installed such that the failure of a single component within the device or system does not prevent normal machine stopping action from taking place...but does prevent a successive machine cycle from being initiated.

CSA (Canadian Standards Association): an independent Canadian testing and standards-making organization similar to Underwriters Laboratories (UL) in the U.S. "CSA-certified" products meet relevant CSA electrical and safety standards.



Declaration of Conformity: a manufacturer's self-certified document, signed by a highly-positioned technical manager, which lists all the Standards and Directives to which a product conforms. A Declaration of Conformity is mandatory for all CE-marked products, and for machine components which, if they fail, could lead to a dangerous or hazardous situation on a machine.

Defined Area: a predetermined area scanned by a light beam within which the presence of an opaque object of specified minimum size will result in the generation of a control signal.

Direct-Action Contacts: See "positive-break" contacts.

Diverse Redundancy: the use of different components and/or different microprocessor instruction sets written by different programmers in the design and construction of redundant components/circuits. Its purpose is to increase system reliability by minimizing the possibility of common-mode failure (the failure of like components used in redundant circuits).

Dual-Channel Safety System: a safety control system characterized by two inputs; each connected to one of two independent safety circuits. Dual-channel systems are typically capable of detecting interconnection wiring faults such as open circuits, short-circuits and ground faults. As such they provide a higher level of safety than single-channel systems.

E-Stop (Emergency Stop): the stopping of a machine by actuation of an "emergency stop" switch (such as a safety interlock switch, emergency push button switch, rope-pull switch, foot switch, or other actuating device).

European Machinery Directive (EMD) 98/392/EEC: a set of machine safety design requirements which must be satisfied to meet the Essential Health and Safety standards established by the European Economic Community. This Directive, and other relevant European Directives (such as the Low Voltage Directive, EMC Directive, et al) must be satisfied for the machine to bear the CE mark.

Fail-to-Danger: a component or system failure which allows a machine to continue operating, exposing personnel to a hazardous or unsafe condition.

Fail-to-Safe: “Fail-to-Safe” safety devices are designed such that a component failure causes the device/system to attain rest in a safe condition.

Fault Detection: the monitoring of selected safety system components whose failure would compromise the functioning of the safety system. The detection of such failures is known as “fault detection.” Examples are:

- a short-circuit in the safety circuit’s interconnection wiring
- an open-circuit in the safety circuit’s interconnection wiring
- a welded contact in the safety controller’s positive-guided relays
- an open machine guard

Fault Exclusion: the ability to minimize known possible component failures (“faults”) in a safety system by design criteria and/or component selection. Simple examples of “excluded faults” are:

- The use of an overrated contactor to preclude the possibility of contact welding.
- Design of a machine guard such that the safety interlock switch actuator cannot be damaged.
- Selection of a suitable safety interlock switch.
- Use of positive-break safety interlock switches together with a self-monitoring safety relay module, such that the possibility of a contact weld resulting in the loss of the safety function is eliminated.

The elimination of such faults are generally a compromise between the technical safety requirements and the theoretical probability of their occurrence. Design engineers are permitted to exclude such faults when constructing the machine’s safety system. However, each “fault exclusion” must be identified, justified, and documented in the Technical File submitted to satisfy the European Machinery Directive.

Feedback Loop: an auxiliary input on a safety controller designed to monitor and detect a contact weld in the primary machine-controlled device (e.g. motor contactor, relay, et al) having positive-guided contacts.

Force-Guided Contacts: See “Positive-Guided Contacts”.

Fixed Barrier Guard: See “Hard Guarding”.

Guard: a barrier that prevents entry of an individual’s hands or other body parts into a hazardous area.

Hard Guarding: the use of screens, fences, or other mechanical barriers to prevent access of personnel to hazardous areas of a machine. “Hard guards” generally allow the operator to view the point-of-operation.

Hazardous Area: an area of a machine or process which presents a potential hazard to personnel.

Interlock: an arrangement in which the operation of one device automatically brings about or prevents the operation of another device.

Interlocked Barrier Guard: a fixed or movable guard which, when opened, stops machine operation.

Machine Primary Control Element (MPCE): an electrically powered component which directly controls a machine’s operation. MPCE’s are the last control component to operate when a machine’s motion is initiated or stopped.

Machine Secondary Control Element (MSCE): a machine control element (other than an MPCE) capable of removing power from the hazardous area (s) of a machine.

Manual Reset: a safety controller reset circuit requiring the presence of a discrete “leading-edge” signal (0V to 24V) to activate the controller’s authorized outputs. A reset button is mandatory.

Manual Start-Up Test: a term applied to safety controllers designed such that at least one of the system’s interlocked machine guards must be manually-opened and closed (after applying power) before machine operation is authorized. All SCHMERSAL’S even numbered Series AES microprocessor--based safety controllers (e.g. AES 1136, AES 1146, AES 1156, AES 3366, et al) are designed to require a manual start-up test.

Monitored-manual Reset: a safety controller reset circuit requiring the presence of a discrete “trailing-edge” signal (24V to 0V) to activate the controller’s authorized outputs. A reset button is mandatory.

Muting: the ability to program a monitoring and/or control device to ignore selected system conditions.

Negative Mode Mounting: the mounting of a single-piece safety interlock switch (e.g. a limit switch) such that the force applied to open the normally closed (NC) safety contact is provided by an internal spring. (See Figure 1.)

In this mounting mode the NC contacts may not open when the safety guard is “open”. Here welded/stuck contacts, or failure of a contact-opening spring, may result in exposing the machine operator to a hazardous/unsafe area.

When mounted in the “negative-mode”, single-piece safety interlock switches can be easily circumvented/defeated by the operator...simply by taping down the switch actuator when the safety guard is open.

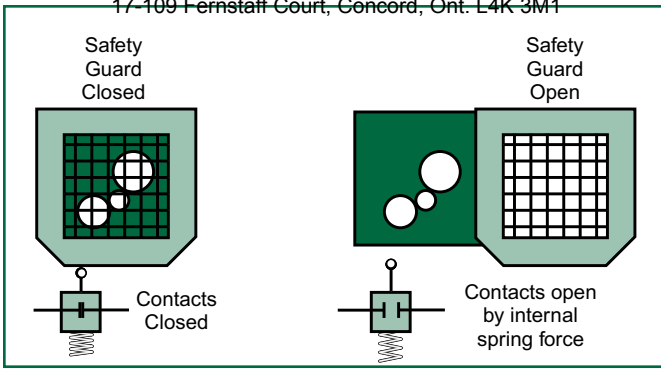

Figure 1

NEGATIVE-MODE INSTALLATION

OSHA (Occupational Safety Health Administration): a U.S. Department of Labor Federal agency responsible for monitoring and regulating workplace safety. OSHA enforcement may reference their own regulations, as well as those of other industry standards-making groups (e.g. ANSI, NFPA, UL, et al).

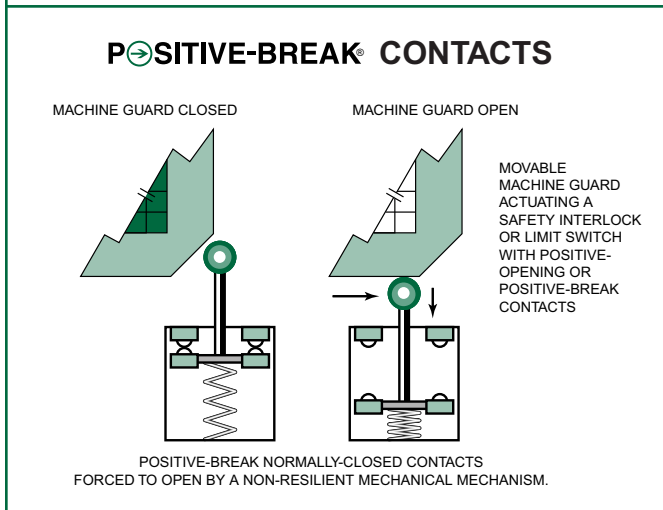
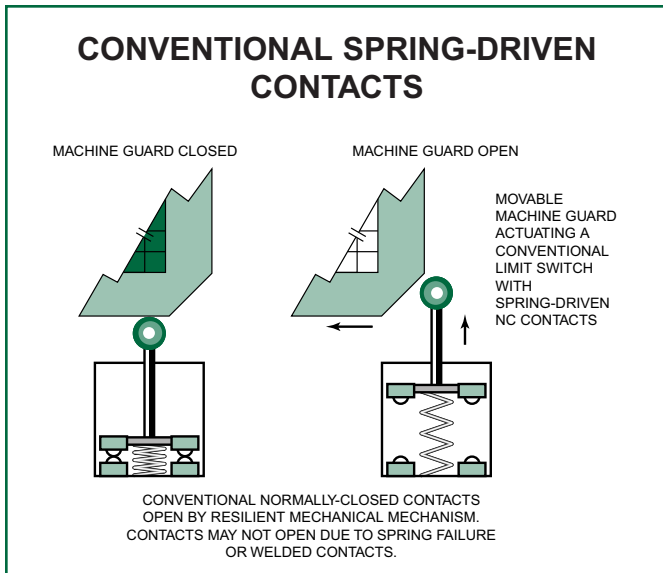

Figure 2

CONVENTIONAL VERSUS POSITIVE-OPENING CONTACTS

Point-of-Operation: the area(s) of a machine where material or the workpiece is positioned and a process is performed.

Point-of-Operation Guarding: a device or guard installed at the interface between the operator and the point-of-operation which is intended to protect personnel from hazardous areas.

Positive-Break Contacts: normally-closed (NC) contacts which, upon actuation, are forced to open by a non-resilient mechanical drive mechanism. Also called “positive-opening” or “direct-action” contacts. (See Figure 2.)

Positive-Guided Contacts: Normally-open (NO) and normally-closed (NC) contacts which operate interdependently such that the NO and NC contacts can never be closed at the same time. They are designed such that if one of the contacts welds/sticks closed, the other contacts cannot change state. (See Figure 3.)

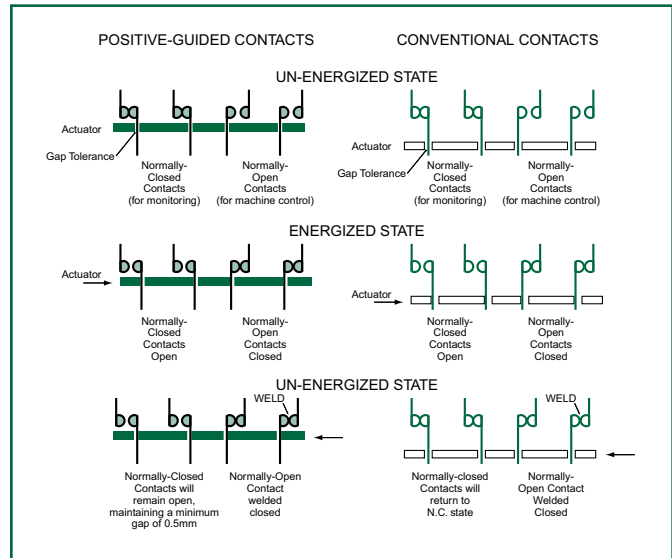

Figure 3

The interdependent operation between NO and NC contacts permits self-checking/monitoring of the functioning of relays and contactors featuring positive-guided contacts. Hence they are desirable in machine safety circuits where “fail-to-safe” or “control reliability” is desired. Also called “force-guided contacts”.

Positive Linkage: a term applied to roller lever, rocking lever and other switch actuating members designed such that the integrity of the linkage between the actuator and the shaft is heightened (beyond a set screw on a smooth shaft) by its mechanical design. Examples of positive-linkages are pinned, square and serrated shafts. (See Figure 4.)

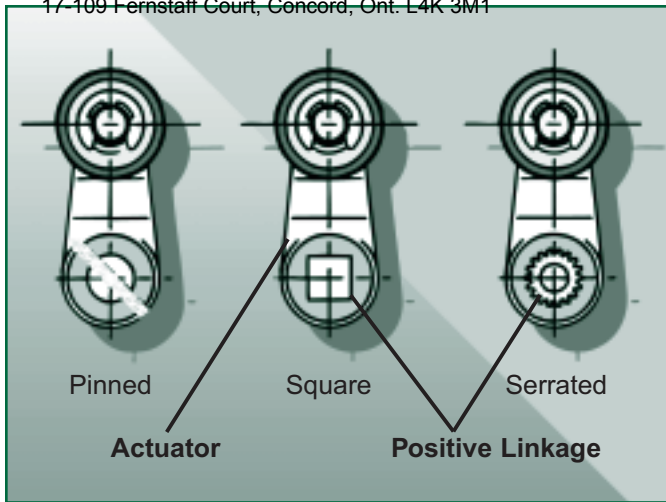

Figure 4

Positive-Mode Mounting: the mounting of a single-piece safety interlock switch (e.g. a limit switch) such that the non-resilient mechanical mechanism which forces the normally-closed (NC) contacts to open is directly driven by the interlocked machine safety guard. In this mode (as opposed to “negative-mode mounting”) the safety guard physically forces the NC contacts to open when the guard is opened. (See Figure 5.)

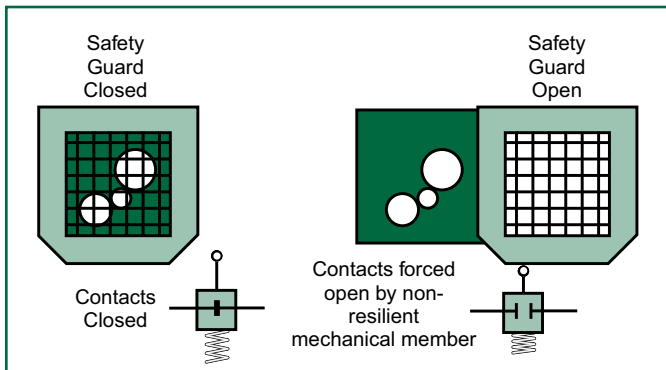

Figure 5

Positive-Opening Contacts: See “Positive-Break Contacts”.

Push/Pull Operation: a term applied to emergency rope-pull switches designed to actuate when the rope/trip-wire is pulled and when it is pushed (goes slack). Such rope-pull switches provide a higher level of safety than units which only actuate when the trip-wire/rope is pulled.

Redundancy: the duplication of control circuits and/or components such that if one component/circuit should fail the other (redundant) component/circuit will ensure safe operation.

Risk Assessment: a systematic means of quantifying the relative level of danger different types of machine hazards present to the machine operator and/or

maintenance personnel. This assessment is usually done in the early stages of the machine’s design to permit such hazards to be designed-out or alternatively determine the scope of the safety system needed to protect personnel from possible injury. One approach suggested in EN954-1 is summarized in Figure 6.

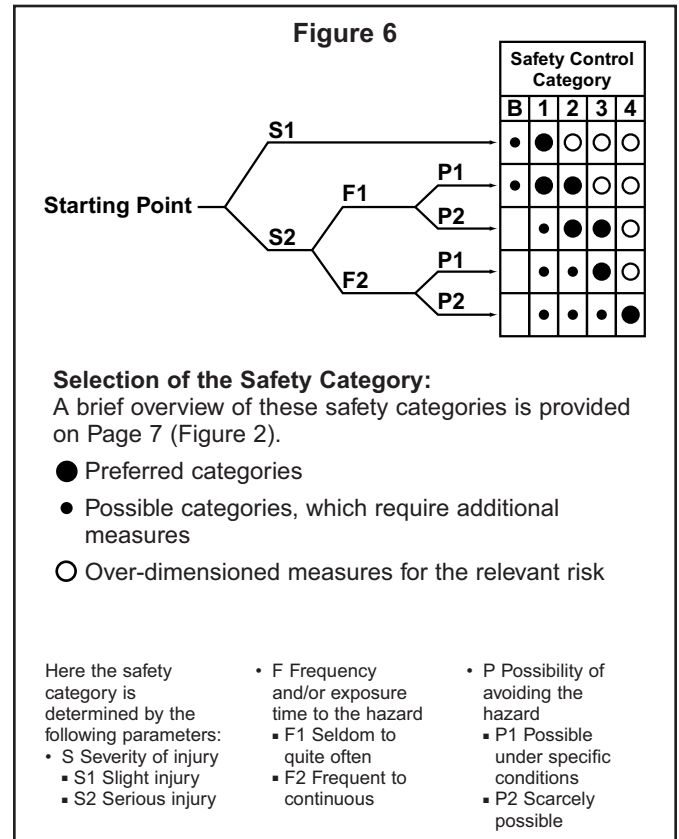

Safeguarding: protecting personnel from hazards using guards, barriers, safety devices and/or safe working procedures.

Safety Controller: an electronic and/or electromechanical device designed expressly for monitoring the integrity of a machine’s safety system. Such controllers are designed using positive-guided (force-guided) relays. Depending upon the model, SCHMERSAL’s safety controllers are capable of detecting the following types of potential safety system faults:

- Machine guard(s) open
- Guard monitoring switch/sensor failure
- Interconnection wiring “open circuit”
- Interconnection wiring “short circuit”
- Interconnection wiring “short-to-ground”
- Welded contact in controlled output device
- Failure of one of the safety controller’s positive-guided relays
- Fault in the safety controller’s monitoring circuit
- Insufficient safety controller operating voltage

Upon detection of a system fault, the safety controller will initiate a “machine stop” command and/or prevent the restarting of the machine until the fault has been corrected. The “stop” command may be immediate or time-delayed depending upon the model safety controller selected.

Safety Enable: (See “Authorized Output.”)

Safety Interlock Switch: a switch designed expressly to safely monitor the position of a machine barrier guard. Such switches typically feature positive-break contacts and are designed to be more tamper-resistant than conventional position/presence-sensing switches.

Safety Output: (See “Authorized Output.”)

Safety Relay: an electromechanical relay designed with positive-guided contacts.

Self-Checking: the performing of periodic self-diagnostics on the safety control circuit to ensure that critical individual components are functioning properly.

Self-Monitoring: see “Self-Checking”.

Single-Channel Safety System: a safety control system characterized by one safety interlock switch whose normally-closed contact is the sole input to a safety controller or a motor contactor. Such systems are unable to detect a short circuit failure in the interconnection wiring and are only recommended for addressing Safety Categories B, 1 and 2 (see “Risk Assessment”).

Solenoid-Latching Safety Interlock Switch: a two-piece safety interlock (actuating key and switch mechanism) whose design prevents the removal of the actuating key until released by an integral latching solenoid. Solenoid latching is typically controlled by a time-delay, motion detector, position sensor or other control components.

Stop Categories:

“0” Requires immediate removal of power from the controlled devices.

“1” Allows for a time delay up to 30 seconds for removal of power. This is commonly used with drive systems where immediate removal of power may result in a longer stop time.

Tamper-Resistant: a term applied to safety interlock switches referring to their relative ability to be defeated or bypassed using simple, readily available means such as a screwdriver, paper clip, piece of tape or wire, etc. Switches and sensors designed expressly for use as machine guard safety interlocks are designed to be more “tamper-resistant” than conventional switches/sensors (e.g. proximity switches, reed switches, conventional limit switches).

Time-delayed Authorized Outputs: a safety controller’s authorized outputs whose activation is delayed (up to 30 seconds) to satisfy Stop Category 1 requirements.

Trailing-edge Reset: (See “Monitored-manual Reset.”)

Two-Hand Control: a machine control system which requires “simultaneous” use of both of the operator’s hands to initiate a machine cycle.

UL (Underwriters Laboratories): an independent testing and standards-making organization. UL tests products for compliance to relevant electrical and safety standards/requirements.

